

Variable Speed Sheaves



 **TB Wood's**[®]
Altra Industrial Motion



**DISTRIBUIDOR
AUTORIZADO**

MEX (55) 53 63 23 31
QRO (442) 1 95 72 60

MTY (81) 83 54 10 18
ventas@industrialmagza.com

TB Wood's

TB Wood's is an industry leading designer and manufacturer of mechanical power transmission equipment for industrial control. Our mechanical product lines include: clutch and brake, synchronous and belted variable speed drives; grid, disc, jaw, gear coupling and elastomeric coupling products; sheaves and bushings. Registered trademarks include Sure-Flex Plus®, Dura-Flex®, G-Flex®, and Sure-Grip®.

TB Wood's was founded in 1857 and began as a foundry producing wood burning stoves. Our company's tradition of product innovation started early. TB Wood's entered the power transmission industry at the turn of the century with the introduction of flat belted drives and line shafting.

VISIT US ON THE WEB AT
TBWOODS.COM



Altra Motion

Altra is a leading global designer and producer of a wide range of electromechanical power transmission and motion control components and systems. Providing the essential control of equipment speed, torque, positioning, and other functions, Altra products can be used in nearly any machine, process or application involving motion. From engine braking systems for heavy duty trucks to precision motors embedded in medical robots to brakes used on offshore wind turbines, Altra has been serving customers around the world for decades.

Altra's leading brands include **Ameridrives**, **Bauer** Gear Motor, **Bibby** Turboflex, **Boston** Gear, **Delevan**, **Delroyd** Worm Gear, **Deltran**, **Formsprag** Clutch, **Guardian** Couplings, **Huco**, **Jacobs** Vehicle Systems, **Kilian**, **Kollmorgen**, **Lamiflex** Couplings, **Marland** Clutch, **Matrix**, **Nuttall** Gear, **Portescap**, **Stieber**, **Stromag**, **Svendborg** Brakes, **TB Wood's**, **Thomson**, **Twiflex**, **Warner** Electric and **Wichita** Clutch.

VISIT US ON THE WEB AT **ALTRAMOTION.COM**



Variable And Wide Range Adjustable Drives

D1



TWO FLANGE MOVEABLE VARIABLE - TWO SPRING

- ALL-PRO** 1 - 30 HP @ 1750 RPM - Dry (no) Lubrication.....D1-2 thru D1-7
MCS 15 - 125 HP @ 1750 RPM - Oil Lubricated.....D1-8 thru D1-13

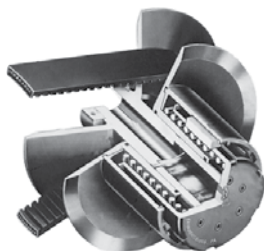

ONE FLANGE MOVEABLE VARIABLE

- MS** 1/2 - 25 HP @ 1750 rpm - Oil Lubricated.....D1-14 thru D1-22
VAR-A-CONE 1/3 - 1-1/2 HP @ 1750 RPM - Dry (no) Lubrication.....D1-32 thru D1-39



TWO FLANGE MOVEABLE

- ROTO-CONE** 1/2 - 30 HP @ 1750 rpm - Grease Lubrication.....D1-24 thru D1-31



WIDE RANGE ADJUSTABLE DRIVES

- VPS** 7-1/2 - 40 HP @ 1750 RPM - No Lubrication.....D1-44 thru D1-48

All-Pro Sheave

Features*

We rotated the keys 45° in our ALL-PRO variable speed sheave, placing them on edge rather than flat to provide a larger shear area for transmitting torque. Thus we eliminated another cause of sheave failure. Then we went further. Resilient keys and permanently lubricated precision machined bushings eliminate fretting corrosion that leads to seizing. Dynamically-balanced, hard-coated aluminum discs reduce inertia, vibration and wear. A keyless collet provides full 360° gripping action and simplifies installation and removal. The ALL-PRO variable speed sheave is designed to operate in the toughest motion-control application.

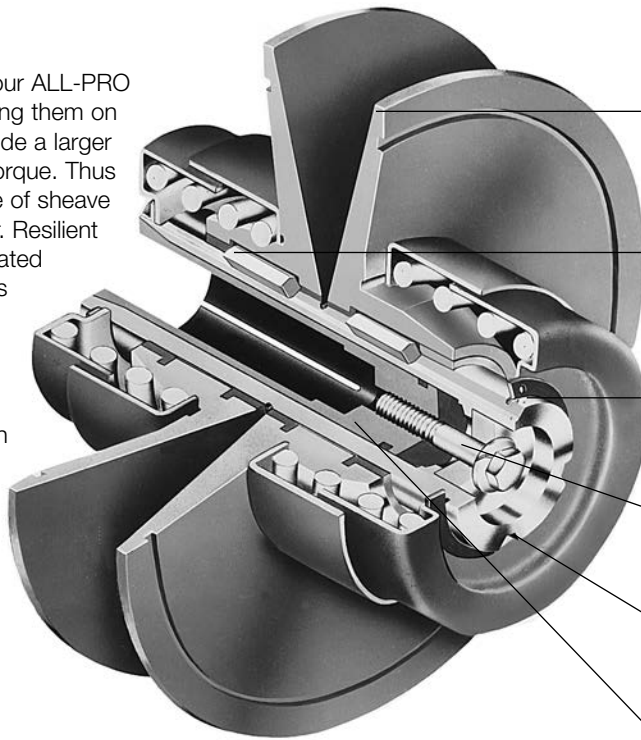

Anodized aluminum disks.

Resilient keys transmit torque from hub to disc. No fretting or corrosion. No maintenance.

Precision machined permanently lubricated metallic bushings provide long maintenance-free life.

Quick change operation—just tighten bolt to secure, loosen and tap to remove sheave.

Push out hole provides easy sheave removal, even after years of use.

Interchangeable collet requires no setscrews or keys.

See the difference . . .

The unique ALL-PRO design provides larger shear area for transmitting torque and dramatically reduces sheave failure.

Conventional

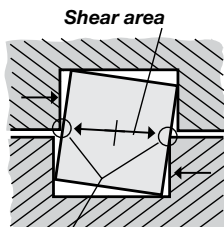

Quadra-Key

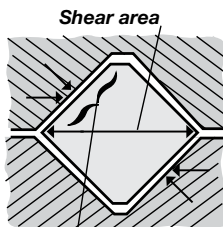

Features

- **Maintenance Free Design**

Resilient keys eliminate need for periodic lubrication and cycling thru speed range.

- **Lightweight Aluminum Construction**

Discs are of aluminum, hard coat anodized to prevent wear. Lightweight construction reduces inertia. Dynamic balancing assures smooth operation.

- **Collet Mounting (excludes AP160M & AP200N)**

Interchangeable collets provide positive, vibration-free sheave to shaft fit and simplify installation and removal.

- **1 thru 30 Horsepower**

Easy on—Easy off

ALL-PRO's easy-on/easy-off collet mounting with 360° gripping action prevents vibration that leads to shaft fretting and burring.

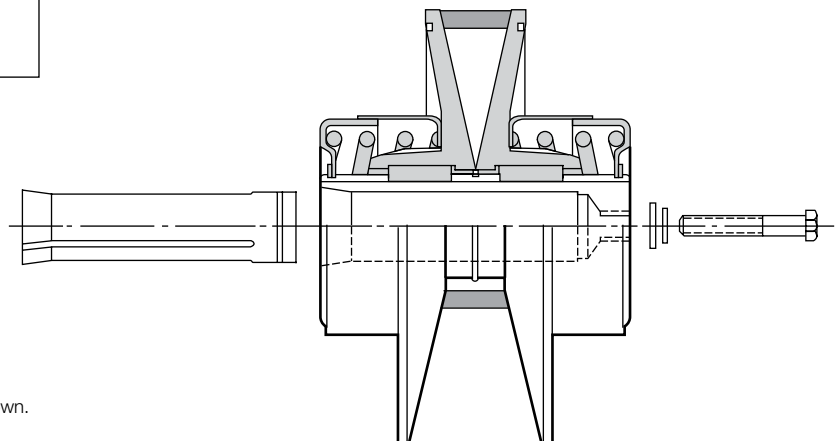

* Note: AP160M & AP200N ALL-PRO sheaves differ from design shown.

Selection

MODEL	HP RATING @			BELT	PITCH DIA.		DRIVE CHART PAGE NO.
	3600	1750	1160		MIN.	MAX.	
AP160M	1-1/2 - 3	1 - 1-1/2	3/4 - 1	1422V	2.05	6.25	D1-4
AP160M	1-1/2 - 3	1 - 1-1/2	3/4 - 1	1922V	2.10	6.30	D1-4
AP200N	-	2 - 5	1 - 3	1922V	2.62	7.87	D1-5
AP225P	-	2 - 5	1 - 3	2322V	2.93	8.80	D1-5
AP260T	-	5 - 10	3 - 7-1/2	2926V	3.42	10.20	D1-6
AP260U	-	5 - 10	3 - 7-1/2	3226V	4.23	10.20	-
AP255W	-	7-1/2 - 15	5 - 10	4430V	4.00	10.00	D1-6
AP255S	-	10 - 20	5 - 10	3230HV	4.00	10.00	D1-7
AP321W	-	7-1/2 - 10	5	4430V	4.25	12.75	D1-7
AP322W	-	10 - 20	5 - 10	4430V	4.25	12.75	D1-7
AP323W	-	15 - 30	10 - 20	4430V	4.25	12.75	D1-7

Horsepower ratings are based on constant torque and are shown for maximum pitch diameters.
Horsepower ratings at other pitch diameters reduce in proportion to the driven speed.

STOCK BORES SIZES

MODEL	COLLET NUMBER	BORE LENGTH	STOCK BORES					MAX. BORE
			7/8	1-1/8	1-3/8	1-5/8	1-7/8	
AP160M*	B.T.S.	2-7/8	X					7/8
AP200N*	B.T.S.	3-1/4	X	X				1-1/8
AP225P	AP1C	3-5/16	X	X				1-3/16
AP260T	AP2C	3-1/2	X	X	X			1-1/2
AP260U	AP2C	3-1/2	X	X	X			1-1/2
AP255W	AP3C	4-3/4			X	X	X	1-15/16
AP255S	AP3C	4-3/4			X	X	X	1-15/16
AP321W	AP3C	4-3/4			X	X	X	1-15/16
AP322W	AP3C	4-3/4			X	X	X	1-15/16
AP323W	AP3C	4-3/4			X	X	X	1-15/16

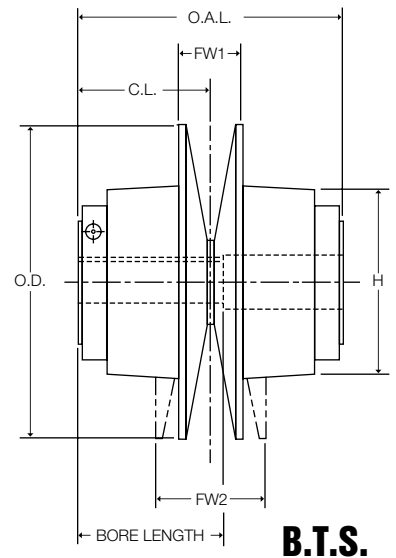

*Can be used in thru bore applications.

ORDERING EXAMPLE: AP200N x 1-1/8
AP225P & AP1C x 1-1/8

ALL-PRO SHEAVE DIMENSIONS

MODEL	O.D.	H	O.A.L.	C.L.	F.W. 1	F.W. 2	WT. LBS.
AP160M	6.50	4.00	5.50	2.75	1.46	2.26	7
AP200N	8.10	5.20	6.13	3.07	1.46	2.47	8.5
AP225P	9.05	5.40	5.75	2.88	1.94	3.00	15.5
AP260T	10.50	5.40	7.48	3.74	2.31	3.81	22.8
AP260U	10.50	5.40	7.48	3.74	2.31	3.81	22.8
AP255W	10.40	6.67	9.60	4.80	3.38	5.00	35.8
AP255S	10.40	6.67	9.60	4.80	2.62	4.25	35.8
AP321W	13.00	6.67	9.60	4.80	3.31	5.56	38.8
AP322W	13.00	6.67	9.60	4.80	3.31	5.56	38.8
AP323W	13.00	6.67	9.60	4.80	3.31	5.56	38.8

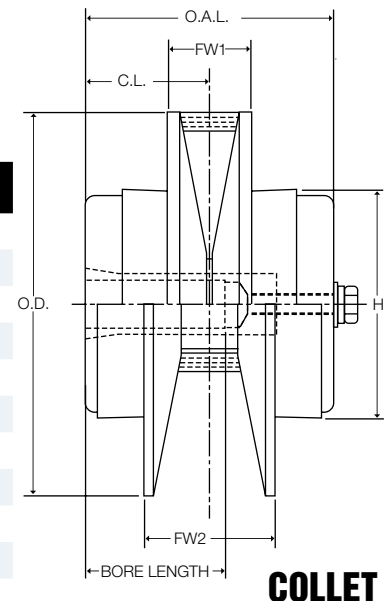

Weight includes collet where used.

Selection Charts

AP160M (1422V BELT)

DRIVEN SPEEDS			PRODUCT NUMBER	GROOVED COMPANION SHEAVE	CENTER DISTANCE IN INCHES AT MAXIMUM AND MINIMUM SPEEDS							
3500 RPM Motor	1750 RPM Motor	1160 RPM Motor			VARIABLE SPEED V-BELT PART NUMBER							
					1422V 360	1422V 420	1422V 480	1422V 540	1422V 600	1422V 660	1422V 720	1422V 780
4167	2083	1381	531M	5.3 x 1M-SH	8.95	11.96	14.96	17.96	20.96	23.96	26.96	29.96
1367	683	453			12.15	15.17	18.19	21.20	24.21	27.21	30.22	33.22
3804	1902	1261	581M	5.8 x 1M-SH	8.57	11.57	14.56	17.57	20.57	23.57	26.57	29.57
1248	624	414			11.72	14.75	17.77	20.78	23.79	26.80	29.81	32.82
3241	1620	1074	681M	6.8 x 1M-SH	7.78	10.79	13.79	16.79	19.79	22.79	25.79	28.79
1063	531	352			10.82	13.87	16.91	19.94	22.96	25.97	28.98	31.99
2833	1411	935	781M	7.8 x 1M-SH	-	9.97	12.98	15.98	18.99	21.99	24.99	27.99
926	463	307			-	12.97	16.03	19.07	22.10	25.13	28.15	31.16
2500	1250	829	881M	8.8 x 1M-SH	-	9.13	12.15	15.16	18.17	21.18	24.18	27.19
820	410	272			-	12.03	15.12	18.19	21.23	24.27	27.29	30.32
2244	1122	744	981M	†9.8 x 1M-SH	-	-	11.29	14.32	17.34	20.35	23.36	26.37
736	368	244			-	-	14.18	17.28	20.34	23.39	26.43	29.46
2035	1017	674	1081M	†10.8 x 1M-SH	-	-	10.39	13.44	16.48	19.51	22.52	25.54
667	334	221			-	-	13.21	16.34	19.43	22.50	25.55	28.59
1862	931	617	1181M	†11.8 x 1M-SH	-	-	-	12.54	15.60	18.64	21.67	24.70
611	305	202			-	-	-	15.37	18.49	21.58	24.65	27.70
1591	795	527	1381M	†13.8 x 1M-SH	-	-	-	-	13.75	16.84	19.91	22.96
522	261	173			-	-	-	-	16.53	19.68	22.80	25.89

AP160M (1922V BELT)

DRIVEN SPEED			PRODUCT NUMBER	GROOVED COMPANION SHEAVE	CENTER DISTANCE IN INCHES AT MAXIMUM AND MINIMUM SPEEDS											
3500 RPM Motor	1750 RPM Motor	1160 RPM Motor			VARIABLE SPEED V-BELT PART NUMBER											
					1922V 443	1922V 460	1922V 526	1922V 604	1922V 646	1922V 686	1922V 721	1922V 751	1922V 806	1922V 891	1922V 1006	1922V 1146
3340	1670	1107	661N	6.6 x 1N-SK	12.0	12.9	16.2	20.1	22.2	24.2	25.9	27.4	30.2	34.4	40.2	47.2
1114	557	369			15.2	16.0	19.4	23.3	25.4	27.4	29.1	30.6	33.4	37.7	43.4	50.4
2900	1450	962	761N	7.6 x 1N-SK	11.2	12.1	15.4	19.3	21.4	23.4	25.1	26.6	29.4	33.6	39.4	46.4
968	484	321			14.3	15.1	18.5	22.4	24.5	26.5	28.3	29.8	32.6	36.8	42.6	49.6
2564	1282	849	861N	8.6 x 1N-SK	10.4	11.3	14.6	18.5	20.6	22.6	24.3	25.8	28.6	32.8	38.6	45.6
854	427	283			13.4	14.2	17.6	21.6	23.7	25.7	27.5	29.0	31.7	36.0	41.8	48.8
2296	1148	761	961N	9.6 x 1N-SK	9.5	10.4	13.7	17.6	19.8	21.8	23.5	25.0	27.8	32.0	37.8	44.8
766	383	254			12.4	13.3	16.7	20.7	22.8	24.8	26.6	28.1	30.9	35.2	41.0	48.0
2080	1040	689	1061N	10.6 x 1N-SK	-	9.5	12.8	16.8	18.9	20.9	22.7	24.2	26.9	31.2	37.0	44.0
694	347	230			-	12.3	15.8	19.8	21.9	24.0	25.7	27.2	30.0	34.3	40.1	47.1
1900	950	630	1161N	11.6 x 1N-SK	-	-	11.9	15.9	18.0	20.1	21.8	23.3	26.1	30.4	36.1	43.1
634	317	210			-	-	14.8	18.8	21.0	23.0	24.8	26.4	29.1	33.4	39.2	46.3
1622	811	537	1361N	13.6 x 1N-SK	-	-	-	14.1	16.3	18.3	20.1	21.6	24.4	28.7	34.5	41.5
540	270	179			-	-	-	16.9	19.1	21.2	23.0	24.6	27.4	31.7	37.5	44.6
1412	706	468	1561N	15.6 x 1N-SK	-	-	-	12.1	14.4	16.4	18.3	19.8	22.6	27.0	32.8	39.8
472	236	156			-	-	-	14.7	17.1	19.2	21.2	22.6	25.5	29.9	35.8	42.9
1252	626	415	1761N	17.6 x 1N-SK	-	-	-	-	-	14.4	16.3	17.9	20.8	25.1	31.0	38.1
418	209	138			-	-	-	-	-	-	17.0	19.0	20.6	23.5	28.0	33.9

Refer to table on page D1—52 for additional belts available.

†Check with factory for availability.

Selection Charts

AP200N (1922V BELT)

DRIVEN SPEED		PRODUCT NUMBER	GROOVED COMPANION SHEAVE	CENTER DISTANCE IN INCHES AT MAXIMUM AND MINIMUM SPEEDS											
1750 RPM Motor	1160 RPM Motor			VARIABLE SPEED V-BELT PART NUMBER											
				1922V 443	1922V 460	1922V 526	1922V 604	1922V 646	1922V 686	1922V 721	1922V 751	1922V 806	1922V 891	1922V 1006	1922V 1146
2086	1383	661N	6.6 x 1N-SK	10.8	11.6	15.0	18.9	21.0	23.0	24.7	26.2	29.0	33.2	39.0	45.9
695	461			14.8	15.6	19.0	22.9	25.0	27.0	28.8	30.3	33.0	37.3	43.0	50.1
1812	1201	761N	7.6 x 1N-SK	10.0	10.9	14.2	18.1	20.2	22.2	23.9	25.4	28.2	32.4	38.2	45.2
604	400			13.9	14.8	18.1	22.0	24.2	26.2	27.9	29.4	32.2	36.4	42.2	49.2
1601	1061	861N	8.6 x 1N-SK	-	10.1	13.4	17.3	19.4	21.4	23.1	24.6	27.4	31.6	37.4	44.4
534	354			-	13.9	17.2	21.2	23.3	25.3	27.1	28.6	31.3	35.6	41.4	48.4
1435	951	961N	9.6 x 1N-SK	-	-	12.5	16.5	18.6	20.6	22.3	23.8	26.6	30.8	36.6	43.6
478	317			-	-	16.3	20.3	22.4	24.5	26.2	27.8	30.5	34.8	40.6	47.6
1299	861	1061N	10.6 x 1N-SK	-	-	11.7	15.7	17.8	19.8	21.5	23.0	25.8	30.0	35.8	42.8
433	287			-	-	15.4	19.4	21.6	23.6	25.4	26.9	29.7	33.9	39.7	46.8
1187	787	1161N	11.6 x 1N-SK	-	-	10.9	14.8	16.9	18.9	20.7	22.2	25.0	29.2	35.0	42.0
396	262			-	-	14.4	18.5	20.6	22.7	24.5	26.0	28.8	33.1	38.9	45.9
1012	671	1361N	13.6 x 1N-SK	-	-	-	13.0	15.2	17.2	19.0	20.5	23.3	27.6	33.3	40.4
337	224			-	-	-	16.6	18.8	20.9	22.7	24.2	27.0	31.3	37.2	44.2
883	585	1561N	15.6 x 1N-SK	-	-	-	-	13.3	15.4	17.2	18.7	21.5	25.8	31.6	38.7
294	195			-	-	-	-	16.7	18.9	20.7	22.3	25.2	29.4	35.4	42.5
782	518	1761N	17.6 x 1N-SK	-	-	-	-	-	-	15.3	16.9	19.7	24.1	29.9	37.0
261	173			-	-	-	-	-	-	-	18.6	20.3	23.2	27.7	33.6

AP225P (2322V BELT)

DRIVEN SPEED		PRODUCT NUMBER	GROOVE COMPANION SHEAVE	CENTER DISTANCE IN INCHES AT MAXIMUM AND MINIMUM SPEEDS										
1750 RPM Motor	1160 RPM Motor			BELT PART NUMBER										
				2322V 441	2322V 481	2322V 521	2322V 541	2322V 601	2322V 661	2322V 681	2322V 721	2322V 801	2322V 1001	2322V 1061
2333	1547	661P	6.6 x 1P-SK	9.89	11.90	13.91	14.91	17.92	20.92	21.92	23.93	27.93	37.94	40.94
777	515			14.44	16.45	18.47	19.47	22.48	25.49	26.50	28.50	32.51	42.52	45.52
2026	1343	761P	7.6 x 1P-SK	-	11.15	13.15	14.15	17.16	20.16	21.16	23.16	27.16	37.16	40.16
675	447			-	15.59	17.61	18.62	21.64	24.66	25.66	27.67	31.69	41.71	44.71
1791	1187	861P	8.6 x 1P-SK	-	10.38	12.38	13.38	16.38	19.38	20.38	22.38	26.38	36.38	39.38
596	395			-	14.70	16.74	17.75	20.78	23.81	24.82	26.83	30.85	40.89	43.89
1604	1063	961P	9.6 x 1P-SK	-	-	11.59	12.59	15.59	18.59	19.59	21.59	25.59	35.59	38.59
534	354			-	-	15.83	16.86	19.91	22.95	23.96	25.98	30.01	40.06	43.07
1433	950	1081P	10.8 x 1P-SK	-	-	-	11.65	14.66	17.66	18.67	20.67	24.67	34.68	37.68
477	316			-	-	-	15.79	18.87	21.93	22.95	24.98	29.02	39.09	42.11
1311	869	1181P	11.8 x 1P-SK	-	-	-	-	13.82	16.84	17.84	19.85	23.86	33.87	36.88
436	289			-	-	-	-	17.95	21.03	22.05	24.09	28.15	38.24	41.26
1120	742	1381P	13.8 x 1P-SK	-	-	-	-	-	15.12	16.13	18.15	22.19	32.23	35.24
373	247			-	-	-	-	-	-	19.15	20.19	22.25	26.36	36.52
978	648	1581P	15.8 x 1P-SK	-	-	-	-	-	-	14.32	16.37	20.45	30.55	33.57
326	216			-	-	-	-	-	-	18.22	20.33	24.99	34.74	37.79
868	575	1781P	17.8 x 1P-SK	-	-	-	-	-	-	-	-	18.63	28.82	31.86
289	191			-	-	-	-	-	-	-	-	-	22.55	32.92

Refer to table on page D1-52 and D1-53 for additional belts available.

Selection Charts

AP260T (2926V BELT)

DRIVEN SPEED		PRODUCT NUMBER	GROOVED COMPANION SHEAVE	CENTER DISTANCE IN INCHES AT MAXIMUM AND MINIMUM SPEEDS							
1750 RPM Motor	1160 RPM Motor			BELT PART NUMBER							
				2926V 574	2926V 606	2926V 646	2926V 686	2926V 726	2926V 834	2926V 906	2926V 1006
2360	1567	761T	7.6 x 1T-SK	14.61	16.22	18.23	20.23	22.24	27.64	31.25	36.25
788	522			19.93	21.53	23.54	25.55	27.56	32.97	36.58	41.59
2086	1383	861T	8.6 x 1T-SK	13.87	15.47	17.47	19.47	21.48	26.88	30.48	35.48
696	461			19.07	20.68	22.70	24.71	26.72	32.14	35.76	40.77
1868	1239	961T	9.6 x 1T-SK	13.10	14.70	16.70	18.70	20.71	26.11	29.71	34.71
623	413			18.19	19.81	21.84	23.86	25.87	31.31	34.92	39.94
1692	1122	1061T	10.6 x 1T-SK	12.32	13.92	15.92	17.92	19.92	25.32	28.92	33.92
565	374			17.29	18.92	20.96	22.99	25.01	30.46	34.08	39.11
1546	1025	1161T	11.6 x 1T-SK	-	13.12	15.12	17.12	19.12	24.53	28.13	33.13
516	342			-	18.01	20.06	22.10	24.13	29.60	33.23	38.27
1319	874	1361T	13.6 x 1T-SK	-	-	13.45	15.47	17.48	22.90	26.51	31.52
440	292			-	-	18.18	20.26	22.32	27.83	31.49	36.55
1150	762	1561T	15.6 x 1T-SK	-	-	-	-	15.75	21.21	24.84	29.86
384	254			-	-	-	-	20.41	26.00	29.69	34.79
1019	676	1761T	17.6 x 1T-SK	-	-	-	-	-	19.45	23.11	28.16
340	225			-	-	-	-	-	24.10	27.84	32.98
915	607	1961T	19.6 x 1T-SK	-	-	-	-	-	17.60	21.31	26.41
305	202			-	-	-	-	-	22.11	25.91	31.11

AP255W (4430V BELT)

DRIVEN SPEED		PRODUCT NUMBER	GROOVED COMPANION SHEAVE	CENTER DISTANCE IN INCHES AT MAXIMUM AND MINIMUM SPEEDS								
1750 RPM Motor	1160 RPM Motor			BELT PART NUMBER								
				4430V 730	4430V 790	4430V 850	4430V 910	4430V 970	4430V 1030	4430V 1090	4430V 1150	4430V 1320
1750	1160	1001W	10.0 x 1W-SF	20.79	23.79	26.79	29.79	32.79	35.79	38.79	41.79	50.29
744	493			25.13	28.15	31.16	34.18	37.19	40.19	43.20	46.21	54.72
1591	1055	1101W	11.0 x 1W-SF	20.00	23.00	26.00	29.00	32.00	35.00	38.00	41.00	49.50
676	448			24.27	27.30	30.32	33.34	36.35	39.36	42.38	45.38	53.91
1458	967	1201W	12.0 x 1W-SF	19.19	22.19	25.20	28.20	31.20	34.20	37.20	40.21	48.71
620	411			23.39	26.43	29.46	32.49	35.51	38.52	41.54	44.45	53.08
1346	892	1301W	13.0 x 1W-SF	18.37	21.38	24.38	27.39	30.39	33.40	36.40	39.40	47.91
572	379			22.50	25.55	28.59	31.62	34.65	37.68	40.70	43.71	52.25
1250	829	1401W	14.0 x 1W-SF	17.52	20.54	23.56	26.57	29.57	32.58	35.59	38.59	47.10
531	352			21.58	24.65	27.70	30.75	33.79	36.82	39.84	42.86	51.41
1167	773	1501W	15.0 x 1W-SF	16.66	19.69	22.71	25.73	28.74	31.76	34.76	37.77	46.29
496	329			20.64	23.73	26.80	29.86	32.91	35.95	38.98	42.01	50.57
1094	725	1601W	16.0 x 1W-SF	15.77	18.82	21.85	24.88	27.90	30.92	33.93	36.94	45.47
465	308			19.68	22.80	25.89	28.96	32.02	35.07	38.11	41.14	49.72
972	644	1801W	18.0 x 1W-SF	-	17.01	20.08	23.14	26.18	29.21	32.24	35.26	43.81
413	274			-	20.85	23.99	27.10	30.19	33.27	36.33	39.38	47.99
875	580	2001W	20.0 x 1W-SF	-	-	18.22	21.31	24.39	27.45	30.49	33.53	42.11
372	247			-	-	22.01	25.17	28.30	31.41	34.50	37.57	46.23
795	527	2201W	22.0 x 1W-SF	-	-	-	19.40	22.52	25.62	28.70	31.76	40.38
338	224			-	-	-	23.16	26.34	29.49	32.61	35.72	44.43
729	483	2201W	22.0 x 1W-SF	-	-	-	-	20.57	23.72	26.83	29.93	38.61
310	205			-	-	-	-	24.29	27.50	30.66	33.80	42.60
625	414	2801W	28.0 x 1W-E	-	-	-	-	-	-	22.86	26.05	34.93
266	176			-	-	-	-	-	-	-	26.53	29.78

Refer to table on page D1-53 for additional belts available.

AP255S (3230HV BELT)

Selection Charts

DRIVEN SPEED		PRODUCT NUMBER	GROOVED COMPANION SHEAVE	CENTER DISTANCE IN INCHES AT MAXIMUM AND MINIMUM SPEEDS									
1750 RPM Motor	1160 RPM Motor			VARIABLE SPEED V-BELT PART NUMBER									
				3230 HV 603	3230 HV 613	3230 HV 626	3230 HV 644	3230 HV 685	3230 HV 702	3230 HV 723	3230 HV 856	3230 HV 960	3230 HV 1060
1842	1221	951S	9.5 x 1S-SF	14.83	15.33	15.98	16.88	18.93	19.78	20.83	27.48	32.68	37.68
783	519			19.16	19.66	20.32	21.22	23.29	24.14	25.20	31.88	37.10	42.11
1750	1160	1001S	10.0 x 1S-SF	14.44	14.94	15.59	16.49	18.54	19.39	20.44	27.09	32.29	37.29
744	493			18.72	19.23	19.88	20.79	22.86	23.72	24.78	31.46	36.68	41.70
1591	1055	1101S	11.0 x 1S-SF	13.64	14.14	14.80	15.70	17.75	18.60	19.65	26.30	31.50	36.50
676	448			17.83	18.34	19.00	19.91	21.99	22.85	23.91	30.62	35.85	40.87
1458	967	1201S	12.0 x 1S-SF	12.83	13.33	13.98	14.88	16.94	17.79	18.84	25.50	30.70	35.70
620	411			16.91	17.43	18.09	19.01	21.10	21.97	23.04	29.76	35.00	40.03
1346	892	1301S	13.0 x 1S-SF	-	12.49	13.14	14.05	16.11	16.96	18.02	24.68	29.89	34.70
572	379			-	16.49	17.16	18.09	20.20	21.07	22.14	28.89	34.15	39.19
1250	829	1401S	14.0 x 1S-SF	-	-	-	13.18	15.26	16.11	17.17	23.86	29.07	34.08
531	352			-	-	-	17.14	19.26	20.14	21.22	28.01	33.28	38.33
1167	773	1501S	15.0 x 1S-SF	-	-	-	-	14.38	15.24	16.31	23.02	28.24	33.26
496	329			-	-	-	-	18.31	19.19	20.28	27.11	32.40	37.46
1094	725	1601S	16.0 x 1S-SF	-	-	-	-	-	14.34	15.42	22.16	27.40	32.43
465	308			-	-	-	-	-	18.21	19.31	26.19	31.51	36.59
972	644	1801S	18.0 x 1S-SF	-	-	-	-	-	-	-	20.39	25.67	30.72
413	274			-	-	-	-	-	-	-	24.31	29.68	34.80
875	580	2001S	20.0 x 1S-SF	-	-	-	-	-	-	-	18.53	23.88	28.97
372	247			-	-	-	-	-	-	-	22.33	27.78	32.96

AP321W, AP322W, & AP323W (4430V BELT)

DRIVEN SPEED		PRODUCT NUMBER	GROOVED COMPANION SHEAVE	CENTER DISTANCE IN INCHES AT MAXIMUM AND MINIMUM SPEEDS								
1750 RPM Motor	1160 RPM Motor			BELT PART NUMBER								
				4430V 730	4430V 790	4430V 850	4430V 910	4430V 970	4430V 1030	4430V 1090	4430V 1150	4430V 1320
2231	1479	1001W	10.0 x 1W-SF	18.57	21.58	24.59	27.59	30.60	33.60	36.60	39.60	48.11
744	493			25.13	28.15	31.16	34.18	37.19	40.19	43.20	46.21	54.72
2028	1345	1101W	11.0 x 1W-SF	17.87	20.82	23.83	26.83	29.83	32.83	35.83	38.83	47.34
676	448			24.27	27.30	30.32	33.34	36.35	39.36	42.38	45.38	53.91
1859	1233	1201W	12.0 x 1W-SF	17.05	20.06	23.06	26.06	29.06	32.06	35.06	38.06	46.56
620	411			23.39	26.43	29.46	32.49	35.51	38.52	41.54	44.55	53.08
1716	1138	1301W	13.0 x 1W-SF	16.27	19.27	22.27	25.27	28.27	31.27	34.27	37.27	45.77
572	379			22.50	25.55	28.59	31.62	34.65	37.68	40.70	43.71	52.25
1594	1056	1401W	14.0 x 1W-SF	15.47	18.48	21.48	24.48	27.48	30.48	33.48	36.48	44.98
531	352			21.58	24.65	27.70	30.75	33.79	36.82	39.84	42.86	51.41
1488	986	1501W	15.0 x 1W-SF	-	17.66	20.67	23.67	26.68	29.68	32.68	35.68	44.19
496	329			-	23.73	26.80	29.86	32.91	35.95	38.98	42.01	50.57
1395	924	1601W	16.0 x 1W-SF	-	16.83	19.84	22.85	25.86	28.87	31.87	34.88	43.38
465	308			-	22.80	25.89	28.96	32.02	35.07	38.11	41.14	49.72
1240	822	1801W	18.0 x 1W-SF	-	-	18.14	21.17	24.19	27.21	30.22	33.23	41.76
413	274			-	-	23.99	27.10	30.19	33.27	36.33	39.38	47.99
1116	740	2001W	20.0 x 1W-SF	-	-	-	19.41	22.46	25.50	28.53	31.55	40.10
372	247			-	-	-	25.17	28.30	31.41	34.50	37.57	46.23
1014	672	2201W	22.0 x 1W-SF	-	-	-	-	20.65	23.72	26.78	29.82	38.40
338	224			-	-	-	-	26.34	29.49	32.61	35.72	44.43
930	616	2401W	24.0 x 1W-SF	-	-	-	-	-	21.87	24.96	28.03	36.67
310	205			-	-	-	-	-	27.50	30.66	33.80	42.60
797	528	2801W	28.0 x 1W-E	-	-	-	-	-	-	-	24.25	33.06
266	176			-	-	-	-	-	-	-	29.78	38.78

Refer to table on page D1-53 for additional belts available.

MCS Sheave

Features



Wood's MCS sheaves incorporate a proven lubrication system that eliminates fretting corrosion, freezing, and sticking. Wood's exclusive cam followers exert side wall pressure on the belt in proportion to the torque required to carry the load. As the load increases, so does the grip on the belt. Thus, constant pitch diameter and constant speed are maintained under varying torque loads. Heavy thrust springs are not constantly squeezing the flanges against the belt and cam pressure is exerted only when the load requires it, greatly prolonging belt life.

- **15 thru 125 HP @ 1750 RPM**
- **Rugged Cast Iron Construction**
- **Dynamically Balanced**
- **V to V Operation**
- **Exclusive Oil Lube Design**
- **Cam Assisted Operation**
- **Proven Reliability**

NOTE: MCS sheaves are not recommended for vertical shaft applications or on applications involving the use of plug reversing or plug stop motors.

Selection Charts

PRODUCT NO.	HP RATING @		BELT	PITCH DIA.		DRIVE CHART PAGE NO.
	1750	1160		MIN.	MAX.	
MCS-10W-HD	15	7-1/2 - 10	4430V	5.00	10.00	D1-10
MCS-12W-HD	15 - 20	7-1/2 - 15	4430V	6.00	12.00	D1-10
MCS-12S	15 - 25	7-1/2 - 15	3230HV	6.00	12.00	D1-11
MCS-13S	*25 - 30	15 - 20	3230HV	6.38	12.75	D1-11
MCS-13-Y	*25 - 40	15 - 30	4836V	6.38	12.75	D1-12
MCS-14-Y	*40 - 60	25 - 40	4836V	7.00	14.00	D1-12
MCS-15-Y	*60 - 125	40 - 75	4836V	10.00	15.00	D1-13

Horsepower ratings are based on constant torque and are shown for maximum pitch diameters.

Horsepower ratings at other pitch diameters reduce in proportion the driven speed.

* Use MBA motor base only.

STOCK BORE SIZES

PRODUCT NO.	1-5/8	1-7/8	2-1/8	2-3/8	2-7/8	MAX. BORE
MCS-10W-HD	X	X	-	-	-	1-7/8
MCS-12W-HD	X	X	-	-	-	1-7/8
MCS-12S ▲	X	X	-	-	-	1-7/8
MCS-13S ▲	-	X	-	-	-	1-7/8
MCS-13-Y ▲	-	X	X	-	-	2-1/8
MCS-14-Y ▲	-	-	X	X	-	2-7/8
MCS-15-Y ▲	-	-	-	X	X	2-7/8

▲ Clamp hub style.

ORDERING EXAMPLE: MCS12S x 1-5/8

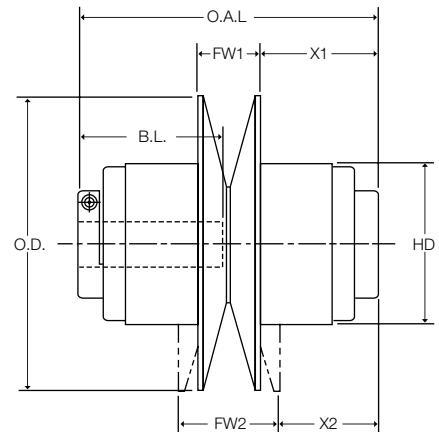

MCS SHEAVE DIMENSIONS

PRODUCT NO.	O.D.	HD	O.A.L.	B.L.	FW 1	X1	FW2	X2	WT. LBS.
MCS-10W-HD	10.40	6-3/4	9-3/4	5-13/16	3-1/4	3.09	4-9/16	2-7/16	57
MCS-12W-HD	12-1/4	6-3/4	9-3/4	5-3/4	3-1/4	3.09	4-13/16	2-5/16	63
MCS-12S	12-1/4	6-3/4	9-9/16	6	2-1/2	3-3/16	4-1/16	2-3/8	69
MCS-13S	13	6-3/4	9-9/16	6	2-1/2	3-3/16	4-3/16	2-5/16	67
MCS-13-Y	13	6-5/8	10-15/16	6	3.40	3-3/8	5-1/2	2.34	72
MCS-14-Y	14.45	9.26	14	7-1/2	3-3/4	4.53	6.02	3.4	200
MCS-15Y	15.45	9.26	14	7-1/2	3-3/4	4.53	5.37	3.72	200

For optional Sight-Lube lubrication system, refer to D1-23.

Selection Charts

MCS-10W-HD (4430V BELT)

DRIVEN SPEED		PRODUCT NUMBER	GROOVED COMPANION SHEAVE	CENTER DISTANCE IN INCHES AT MAXIMUM AND MINIMUM SPEEDS												
1750 RPM Motor	1160 RPM Motor			VARIABLE SPEED V-BELT NUMBER												
				4430V 555	4430V 576	4430V 610	4430V 630	4430V 660	4430V 690	4430V 730	4430V 790	4430V 850	4430V 910	4430V 970	4430V 1090	4430V 1320
2188	1450	801W	8.0 x 1W-SF	13.5	14.7	16.2	17.2	18.7	20.2	22.2	25.2	31.2	34.2	40.2	51.7	
1094	725			17.4	18.6	20.1	21.2	22.6	24.1	26.1	29.1	32.1	35.1	38.1	44.1	55.6
2059	1365	851W	8.5 x 1W-SF	13.1	14.3	15.8	16.8	18.3	19.8	21.8	24.8	27.8	30.8	33.8	39.8	51.3
1029	682			16.9	18.2	19.7	20.7	22.2	23.7	25.7	28.7	31.7	34.7	37.7	43.7	55.2
1944	1299	901W	9.0 x 1W-SF	12.7	13.9	15.4	16.4	17.9	19.4	21.4	24.4	27.4	30.4	33.5	39.5	51.0
972	644			16.5	17.8	19.3	20.3	21.8	23.3	25.3	28.3	31.3	34.3	37.3	43.3	54.8
1842	1221	951W	9.5 x 1W-SF	12.3	13.6	15.1	16.1	17.6	19.1	21.0	24.0	27.0	30.1	33.1	39.1	50.6
921	611			16.1	17.3	18.9	19.9	21.4	22.9	24.9	27.9	30.9	33.9	36.9	42.9	54.4
1750	1160	1001W	10.0 x 1W-SF	11.9	13.2	14.7	15.7	17.2	18.7	20.7	23.7	26.7	29.7	32.7	38.7	50.2
875	580			15.6	16.9	18.4	19.4	20.9	22.5	24.5	27.5	30.5	33.5	36.5	42.5	54.0
1591	1054	1101W	11.0 x 1W-SF	11.0	12.4	13.9	14.9	16.4	17.9	19.9	22.9	25.9	28.9	31.9	37.9	49.4
795	527			14.7	16.0	17.6	18.6	20.1	21.6	23.6	26.6	29.7	32.7	35.7	41.7	53.2
1458	967	1201W	12.0 x 1W-SF	-	11.6	13.1	14.1	15.6	17.1	19.1	22.1	25.1	28.1	31.1	37.1	48.6
729	483			-	15.1	16.7	17.7	19.2	20.7	22.7	25.8	28.8	31.8	34.8	40.9	52.4
1346	892	1301W	13.0 x 1W-SF	-	-	12.4	13.2	14.7	16.2	18.2	21.2	24.3	27.3	30.3	36.3	47.8
673	446			-	-	15.9	16.8	18.3	19.8	21.9	24.9	28.0	31.0	34.0	40.0	51.6
1250	828	1401W	14.0 x 1W-SF	-	-	-	12.5	13.9	15.4	17.4	20.4	23.4	26.5	29.5	35.5	47.0
625	414			-	-	-	16.0	17.3	18.9	21.0	24.0	27.1	30.1	33.2	39.2	50.8
1167	773	1501W	15.0 x 1W-SF	-	-	-	-	13.2	14.5	16.5	19.6	22.6	25.6	28.6	34.7	46.2
583	387			-	-	-	-	16.5	18.0	20.0	23.1	26.2	29.2	32.3	38.3	49.9
1094	725	1601W	16.0 x 1W-SF	-	-	-	-	-	13.8	15.7	18.7	21.7	24.8	27.8	33.8	45.4
547	363			-	-	-	-	-	17.1	19.1	22.2	25.3	28.3	31.4	37.5	49.1
972	644	1801W	18.0 x 1W-SF	-	-	-	-	-	-	-	16.9	20.0	23.0	26.1	32.1	43.7
486	322			-	-	-	-	-	-	-	-	19.2	24.4	26.5	29.6	35.7
875	580	2001W	20.0 x 1W-SF	-	-	-	-	-	-	-	-	18.1	21.2	24.3	30.4	42.0
438	290			-	-	-	-	-	-	-	-	-	21.4	24.6	22.7	33.9
795	527	2201W	22.0 x 1W-SF	-	-	-	-	-	-	-	-	-	19.3	22.4	28.6	40.3
398	264			-	-	-	-	-	-	-	-	-	-	22.6	25.8	32.0
729	483	2401W	24.0 x 1W-SF	-	-	-	-	-	-	-	-	-	-	20.5	26.8	38.5
365	242			-	-	-	-	-	-	-	-	-	-	-	23.7	30.1
625	414	2801W	28.0 x 1W-E	-	-	-	-	-	-	-	-	-	-	-	22.9	35.0
312	207			-	-	-	-	-	-	-	-	-	-	-	-	26.1

MCS-12W-HD (4430V BELT)

DRIVEN SPEED		PRODUCT NUMBER	GROOVED COMPANION SHEAVE	CENTER DISTANCE IN INCHES AT MAXIMUM AND MINIMUM SPEEDS													
1750 RPM Motor	1160 RPM Motor			VARIABLE SPEED V-BELT NUMBER													
				4430V 555	4430V 578	4430V 610	4430V 630	4430V 660	4430V 690	4430V 730	4430V 790	4430V 850	4430V 910	4430V 970	4430V 1090	4430V 1320	
2625	1740	801W	8.0 x 1W-SF	11.8	13.0	14.5	15.5	17.1	18.6	20.6	23.6	26.6	29.6	32.6	38.6	50.1	
1313	870			16.6	17.9	19.4	20.4	21.9	23.4	25.3	28.3	31.3	34.4	37.4	43.4	54.9	
2470	1638	851W	8.5 x 1W-SF	11.4	12.7	14.2	15.2	16.7	18.2	20.2	23.2	26.2	29.2	32.2	38.2	49.7	
1235	819			16.2	17.4	18.9	19.9	21.5	23.0	24.9	27.9	30.9	34.0	37.0	43.0	54.5	
2333	1547	901W	9.0 x 1W-SF	10.7	12.3	13.8	14.8	16.3	17.8	19.8	22.8	25.8	28.8	31.9	37.9	49.4	
1167	773			15.9	17.0	18.5	19.5	21.0	22.5	24.5	27.5	30.5	33.6	36.6	42.6	54.1	
2210	1465	951W	9.5 x 1W-SF	-	11.9	13.4	14.4	15.9	17.4	19.4	22.4	25.5	28.5	31.5	37.5	49.0	
1105	733			-	16.6	18.1	19.1	20.6	22.1	24.1	27.1	30.1	33.2	36.2	42.2	53.7	
2100	1392	1001W	10.0 x 1W-SF	-	11.6	13.1	14.1	15.6	17.1	19.1	22.1	25.1	28.1	31.1	37.1	48.6	
1050	696			-	16.2	17.7	18.7	20.2	21.7	23.7	26.7	29.7	32.8	35.8	41.8	53.3	
1909	1265	1101W	11.0 x 1W-SF	-	-	12.4	13.3	14.7	16.3	18.3	21.3	24.3	27.3	30.3	36.3	47.8	
954	633			-	-	17.0	17.9	19.3	20.9	22.9	25.9	28.9	31.9	34.9	40.9	52.5	
1750	1160	1201W	12.0 x 1W-SF	-	-	-	12.7	14.0	15.5	17.5	20.5	23.5	26.5	29.5	35.5	47.0	
875	580			-	-	-	17.2	18.5	20.0	22.0	25.0	28.1	31.1	34.1	40.1	51.7	
1615	1071	1301W	13.0 x 1W-SF	-	-	-	-	13.4	14.7	16.7	19.7	22.7	25.7	28.7	34.7	46.2	
808	535			-	-	-	-	17.7	19.1	21.2	24.2	27.2	30.3	33.3	39.3	50.8	
1500	994	1401W	14.0 x 1W-SF	-	-	-	-	-	14.1	15.9	18.9	21.9	24.9	27.9	33.9	45.4	
750	497			-	-	-	-	-	-	18.4	20.3	23.3	26.4	29.4	32.4	38.5	50.0
1400	928	1501W	15.0 x 1W-SF	-	-	-	-	-	-	15.1	18.1	21.1	24.1	27.1	33.1	44.7	
700	464			-	-	-	-	-	-	19.3	21.4	25.5	28.5	31.6	37.6	49.2	
1313	870	1601W	16.0 x 1W-SF	-	-	-	-	-	-	-	-	17.3	20.3	23.3	26.3	32.3	43.8
656	435			-	-	-	-	-	-	-	-	21.5	24.6	27.6	30.7	36.8	48.3
1167	773	1801W	18.0 x 1W-SF	-	-	-	-	-	-	-	-	18.6	21.6	24.6	30.7	42.2	
583	387			-	-	-	-	-	-	-	-	-	22.7	25.8	28.9	35.0	46.6
1050	696	2001W	20.0 x 1W-SF	-	-	-	-	-	-	-	-	16.8	19.8	22.9	29.0	40.6	
525	348			-	-	-	-	-	-	-	-	-	20.8	23.9	27.1	33.2	44.9
954	633	2201W	22.0 x 1W-SF	-	-	-	-	-	-	-	-	-	18.1	21.1	27.2	38.9	
477	316			-	-	-	-	-	-	-	-	-	-	22.0	25.1	31.4	43.2
875	580	2401W	24.0 x 1W-SF	-	-	-	-	-	-	-	-	-	-	19.2	25.4	37.1	
438	290			-	-	-	-	-	-	-	-	-	-	-	23.1	29.4	41.3
750	497	2801W	28.0 x 1W-E	-	-	-	-	-	-	-	-	-	-	-	-	33.6	
375	248			-	-	-	-	-	-	-	-	-	-	-	-	-	37.7

Refer to table on page D1-53 for additional belts available.

MCS-12S (3230HV BELT)

DRIVEN SPEED		PRODUCT NUMBER	GROOVED COMPANION SHEAVE	CENTER DISTANCE IN INCHES AT MAXIMUM AND MINIMUM SPEEDS													
1750 RPM Motor	1160 RPM Motor			VARIABLE SPEED V-BELT NUMBER													
				3230 HV 585	3230 HV 603	3230 HV 613	3230 HV 620	3230 HV 626	3230 HV 644	3230 HV 670	3230 HV 685	3230 HV 702	3230 HV 723	3230 HV 821	3230 HV 931	3230 HV 960	3230 HV 1060
2210	1465	951S	9.5 x 1S-SF	12.3	13.2	13.7	14.1	14.4	15.3	16.6	17.3	18.2	19.2	24.3	25.9	31.1	36.1
1105	733			17.0	17.9	18.4	18.7	19.0	20.0	21.3	22.0	22.9	23.9	28.8	30.6	35.8	40.8
2100	1392	1001S	10.0 x 1S-SF	11.9	12.8	13.3	13.7	14.0	14.9	16.2	16.9	17.8	18.9	23.9	25.6	30.7	35.7
1050	696			16.6	17.5	18.0	18.3	18.6	19.5	20.8	21.6	22.5	23.5	28.4	30.2	35.5	40.4
1909	1265	1101S	11.0 x 1S-SF	-	12.1	12.6	12.9	13.2	14.1	15.4	16.2	17.0	18.1	23.0	24.3	29.9	34.9
955	633			-	16.8	17.1	17.5	17.8	18.7	20.0	20.8	21.6	22.7	27.6	29.4	34.6	39.6
1750	1160	1201S	12.0 x 1S-SF	-	-	-	-	12.4	13.4	14.7	15.4	16.3	17.3	22.3	24.0	29.2	34.2
875	580			-	-	-	-	16.9	17.8	19.1	19.9	20.7	21.8	26.8	28.5	33.7	38.8
1615	1071	1301S	13.0 x 1S-SF	-	-	-	-	-	12.5	13.9	14.6	15.5	16.5	21.4	23.2	28.3	33.4
807	535			-	-	-	-	-	16.9	18.2	19.0	19.9	20.9	25.9	27.7	32.9	37.9
1500	994	1401S	14.0 x 1S-SF	-	-	-	-	-	-	-	13.8	14.6	15.7	20.7	22.4	27.6	32.6
750	497			-	-	-	-	-	-	-	-	18.1	19.0	20.0	25.0	26.8	32.1
1400	928	1501S	15.0 x 1S-SF	-	-	-	-	-	-	-	-	13.8	14.9	20.0	21.6	26.8	31.3
700	464			-	-	-	-	-	-	-	-	-	18.1	19.1	24.6	26.0	31.2
1312	870	1601S	16.0 x 1S-SF	-	-	-	-	-	-	-	-	-	-	19.1	20.8	25.9	30.9
656	435			-	-	-	-	-	-	-	-	-	-	-	23.2	25.1	30.3
1166	733	1801S	18.0 x 1S-SF	-	-	-	-	-	-	-	-	-	-	17.3	19.0	24.3	29.3
583	386			-	-	-	-	-	-	-	-	-	-	-	21.4	23.2	28.5
1050	696	2001S	20.0 x 1S-SF	-	-	-	-	-	-	-	-	-	-	-	17.2	22.5	27.6
525	348			-	-	-	-	-	-	-	-	-	-	-	-	21.2	26.7

MCS-13S (3230HV BELT)

DRIVEN SPEED		PRODUCT NUMBER	GROOVED COMPANION SHEAVE	CENTER DISTANCE IN INCHES AT MAXIMUM AND MINIMUM SPEEDS													
1750 RPM Motor	1160 RPM Motor			VARIABLE SPEED V-BELT NUMBER													
				3230 HV 585	3230 HV 603	3230 HV 613	3230 HV 620	3230 HV 626	3230 HV 644	3230 HV 670	3230 HV 685	3230 HV 702	3230 HV 723	3230 HV 821	3230 HV 931	3230 HV 960	3230 HV 1060
2348	1557	951S	9.5 x 1S-SF	11.7	12.6	13.1	13.4	13.7	14.6	15.9	16.7	17.5	18.6	23.6	29.1	30.5	35.5
1175	779			16.7	17.6	18.1	18.5	18.8	19.7	21.0	21.7	22.6	23.6	28.6	34.1	35.5	40.5
2231	1479	1001S	10.0 x 1S-SF	-	12.0	12.7	13.1	13.4	14.3	15.6	16.3	17.2	18.2	23.3	28.7	30.1	35.1
1116	740			-	17.2	17.7	18.0	18.3	19.2	20.6	21.3	22.2	23.2	28.2	33.7	35.1	40.1
2028	1344	1101S	11.0 x 1S-SF	-	-	-	12.3	12.6	13.5	14.8	15.6	16.4	17.5	22.5	27.9	29.3	34.3
1015	673			-	-	-	17.2	17.5	18.4	19.7	20.5	21.3	22.4	27.4	33.0	34.3	39.3
1859	1232	1201S	12.0 x 1S-SF	-	-	-	-	-	12.8	14.0	14.8	15.7	16.7	21.7	27.1	28.6	33.6
930	617			-	-	-	-	-	17.5	18.9	19.6	20.5	21.5	26.5	32.0	33.4	38.5
1784	1183	1301S	13.0 x 1S-SF	-	-	-	-	-	-	13.3	14.0	14.9	15.9	20.9	26.4	27.8	32.8
858	569			-	-	-	-	-	-	18.0	18.7	19.6	20.7	25.7	31.2	32.6	37.6
1593	1056	1401S	14.0 x 1S-SF	-	-	-	-	-	-	-	-	14.1	15.1	20.2	25.5	27.0	32.0
737	488			-	-	-	-	-	-	-	-	-	18.7	19.8	24.8	30.4	31.8
1487	986	1501S	15.0 x 1S-SF	-	-	-	-	-	-	-	-	-	14.3	19.3	24.8	26.2	31.2
744	493			-	-	-	-	-	-	-	-	-	-	18.9	23.9	29.5	30.9
1394	924	1601S	16.0 x 1S-SF	-	-	-	-	-	-	-	-	-	-	18.6	24.0	25.4	30.4
697	463			-	-	-	-	-	-	-	-	-	-	-	23.0	28.6	30.1
1240	822	1801S	18.0 x 1S-SF	-	-	-	-	-	-	-	-	-	-	16.8	22.3	23.7	28.8
620	411			-	-	-	-	-	-	-	-	-	-	-	21.1	27.4	28.3
1115	740	2001S	20.0 x 1S-SF	-	-	-	-	-	-	-	-	-	-	-	20.5	22.0	27.0
558	370			-	-	-	-	-	-	-	-	-	-	-	-	24.9	26.4

Refer to table on page D1-53 for additional belts available.

Selection Charts

MCS-13-Y (4836V BELT)

DRIVEN SPEED		PRODUCT NUMBER	GROOVED COMPANION SHEAVE	CENTER DISTANCE IN INCHES AT MAXIMUM AND MINIMUM SPEEDS										
1750 RPM Motor	1160 RPM Motor			VARIABLE SPEED V-BELT PART NUMBER										
				4836V 670	4836V 710	4836V 800	4836V 850	4836V 900	4836V 950	4836V 1000	4836V 1060	4836V 1120	4836V 1180	4836V 1250
2231	1479	1001Y	†10.0 x 1Y-F	15.6	17.6	22.1	24.6	27.1	29.6	32.1	35.1	38.1	41.1	44.6
1117	740			20.6	22.6	27.1	29.6	32.1	34.6	37.1	40.1	43.1	46.1	49.6
2028	1345	1101Y	†11.0 x 1Y-F	14.8	16.8	21.3	23.8	26.3	28.8	31.3	34.3	37.3	40.3	43.8
1015	673			19.7	21.7	26.3	28.8	31.3	33.8	36.3	39.3	42.3	45.3	48.8
1859	1233	1201Y	12.0 x 1Y-F	14.1	16.1	20.6	23.1	25.6	28.1	30.6	33.6	36.6	39.6	43.1
930	617			18.9	20.9	25.4	27.9	30.4	33.0	35.5	38.5	41.5	44.5	48.0
1594	1056	1401Y	14.0 x 1Y-F	-	14.5	19.0	21.5	24.0	26.5	29.0	32.0	35.0	38.0	41.5
798	529			-	19.1	23.7	26.2	28.7	31.3	33.8	36.8	39.8	42.8	46.3
1395	924	1601Y	16.0 x 1Y-F	-	-	17.3	19.9	22.4	24.9	27.4	30.4	33.4	36.4	39.9
698	463			-	-	21.9	24.5	27.0	29.5	32.1	35.1	38.1	41.1	44.7
1240	822	1801Y	18.0 x 1Y-F	-	-	-	18.2	20.7	23.2	25.7	28.7	31.8	34.8	38.3
620	411			-	-	-	22.6	25.2	27.8	30.3	33.4	36.4	39.4	43.0
1116	740	2001Y	20.0 x 1Y-F	-	-	-	-	18.9	21.5	24.0	27.0	30.1	33.1	36.6
558	370			-	-	-	-	23.3	25.9	28.5	31.5	34.6	37.7	41.2
930	616	2401Y	24.0 x 1Y-F	-	-	-	-	-	-	20.4	23.5	26.6	29.6	33.2
465	308			-	-	-	-	-	-	24.6	27.7	30.9	34.0	37.6
744	493	3001Y	30.0 x 1Y-F	-	-	-	-	-	-	-	-	-	23.9	27.6
372	247			-	-	-	-	-	-	-	-	-	-	28.0

† This companion sheave only recommended for 30 HP @ 1750 RPM & 20 HP @ 1160 RPM.

MCS-14-Y (4836V BELT)

DRIVEN SPEED		PRODUCT NUMBER	GROOVED COMPANION SHEAVE	CENTER DISTANCE IN INCHES AT MAXIMUM AND MINIMUM SPEEDS										
1750 RPM Motor	1160 RPM Motor			VARIABLE SPEED V-BELT PART NUMBER										
				4836V 670	4836V 710	4836V 750	4836V 850	4836V 900	4836V 950	4836V 1000	4836V 1060	4836V 1120	4836V 1180	4836V 1250
2450	1624	1001Y	†10.0 x 1Y-F	14.5	16.5	18.6	23.6	26.1	28.6	31.1	34.1	37.1	40.1	43.6
1225	812			20.1	22.1	24.1	29.1	31.6	34.1	36.6	39.6	42.6	45.6	49.1
2227	1476	1101Y	†11.0 x 1Y-F	13.8	15.8	17.8	22.8	25.3	27.8	30.3	33.3	36.3	39.3	42.8
1114	738			19.3	21.3	23.3	28.3	30.8	33.3	35.8	38.8	41.8	44.8	48.3
2042	1353	1201Y	†12.0 x 1Y-F	-	15.0	17.0	22.1	24.6	27.1	29.6	32.6	35.6	38.6	42.1
1021	677			-	20.4	22.4	27.5	30.0	32.5	35.0	38.0	41.0	44.0	47.5
1750	1160	1401Y	14.0 x 1Y-F	-	-	15.5	20.5	23.0	25.5	28.0	31.0	34.0	37.0	40.5
875	580			-	-	20.7	25.8	28.3	30.8	33.3	36.4	39.4	42.4	45.9
1531	1015	1601Y	16.0 x 1Y-F	-	-	-	18.9	21.4	23.9	26.4	29.4	32.4	35.4	38.9
766	508			-	-	-	24.0	26.5	29.1	31.6	34.6	37.7	40.7	44.2
1361	902	1801Y	18.0 x 1Y-F	-	-	-	17.3	19.8	22.3	24.8	27.8	30.8	33.8	37.3
681	451			-	-	-	22.2	24.8	27.3	29.9	32.9	36.0	39.0	42.5
1225	812	2001Y	20.0 x 1Y-F	-	-	-	-	18.1	20.6	23.1	26.1	29.2	32.2	35.7
613	406			-	-	-	-	22.9	25.5	28.1	31.1	34.2	37.2	40.8
1021	677	2401Y	24.0 x 1Y-F	-	-	-	-	-	-	-	22.6	25.7	28.7	32.3
510	338			-	-	-	-	-	-	-	27.3	30.5	33.6	37.2
816	541	3001Y	30.0 x 1Y-F	-	-	-	-	-	-	-	-	-	23.1	26.8
408	270			-	-	-	-	-	-	-	-	-	-	27.6

† This companion sheave only recommended for 50 HP @ 1750 RPM & 30 HP @ 1160 RPM.

Refer to table on page D1—53 for additional belts available.

MCS-15-Y (4836V BELT)

DRIVEN SPEED		PRODUCT NUMBER	GROOVED COMPANION SHEAVE	CENTER DISTANCE IN INCHES AT MAXIMUM AND MINIMUM SPEEDS									
1750 RPM Motor	1160 RPM Motor			VARIABLE SPEED V-BELT PART NUMBER									
				4836V 710	4836V 750	4836V 850	4836V 900	4836V 950	4836V 1000	4836V 1060	4836V 1120	4836V 1180	4836V 1250
2625	1740	1001Y	†10.0 x 1Y-F	15.7	17.7	22.7	25.2	27.8	30.3	33.3	36.3	39.3	42.8
1750	1160			19.8	21.8	26.8	29.3	31.8	34.3	37.3	40.3	43.3	46.8
2386	1582	1101Y	†11.0 x 1Y-F	14.94	17.0	22.0	24.5	27.0	29.5	32.5	35.5	38.5	42.0
1590	1054			19.0	21.0	26.0	28.5	31.0	33.5	36.5	39.5	42.5	46.0
2188	1450	1201Y	†12.0 x 1Y-F	-	16.2	21.2	23.8	26.3	28.8	31.8	34.8	37.8	41.3
1458	967			-	20.2	25.2	27.7	30.2	32.7	35.7	38.7	41.7	45.2
1875	1242	1401Y	14.0 x 1Y-F	-	-	19.7	22.2	24.7	27.2	30.2	33.2	36.2	39.7
1250	828			-	-	23.6	26.1	28.6	31.1	34.1	37.1	40.1	43.6
1640	1088	1601Y	16.0 x 1Y-F	-	-	18.2	20.6	23.2	25.6	28.6	31.7	34.6	38.2
1094	725			-	-	21.9	24.4	26.9	29.4	32.4	35.4	38.5	42.0
1458	967	1801Y	18.0 x 1Y-F	-	-	-	19.0	21.5	24.0	27.0	30.0	33.0	36.5
972	644			-	-	-	22.7	25.2	27.7	30.8	33.8	36.8	40.3
1313	870	2001Y	20.0 x 1Y-F	-	-	-	-	19.9	22.4	25.4	28.4	31.4	34.9
875	580			-	-	-	-	23.4	26.0	29.0	32.1	35.1	38.6
1094	725	2401Y	24.0 x 1Y-F	-	-	-	-	-	-	21.9	25.0	28.0	31.5
729	483			-	-	-	-	-	-	25.3	28.4	31.5	35.1
875	580	3001Y	30.0 x 1Y-F	-	-	-	-	-	-	-	-	-	26.1
583	386			-	-	-	-	-	-	-	-	-	-

† This companion sheave only recommended for 75 HP @ 1750 RPM & 50 HP @ 1160 RPM.

Refer to table on page D1—53 for additional belts available.

MS Sheave

Features

Wood's MS variable speed drives allow smooth, infinitely variable speed changes without stopping the drive. MS oil lube sheaves employ a revolutionary design that assures continuous, positive lubrication of all moving parts. Single flange moving, they are designed for use with either a flat companion pulley or grooved companion sheave. Capacities from 1/2 to 25 HP @ 1750 RPM. Precision balanced, proven reliability.

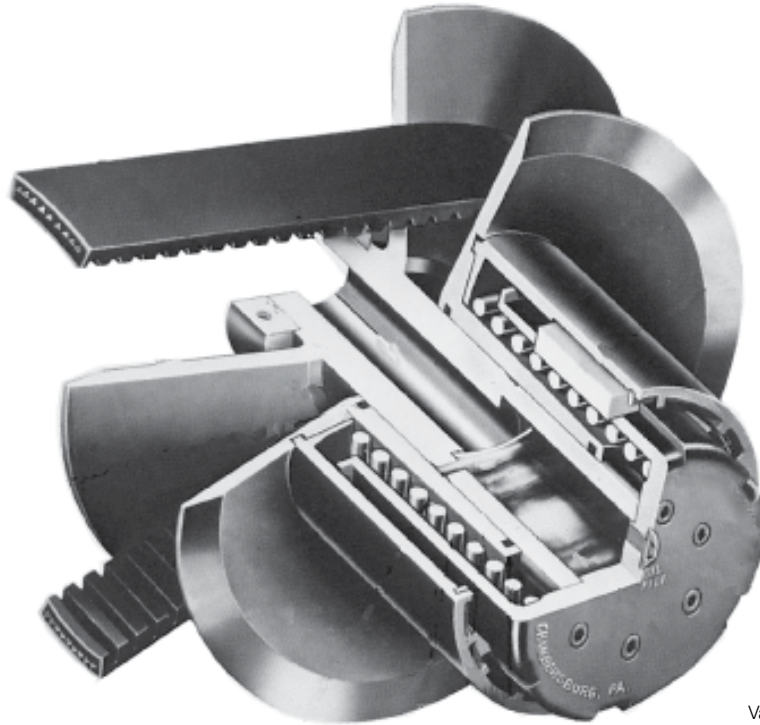

MS
Motion Control
Variable Speed Pulley
U.S. Pat. 2.952.161

Wood's exclusive oil lubrication system is shown in this view of a MS sheave. From a built-in reservoir, oil is continually pumped onto the surface of the sleeve, where it spreads to form an oil film that covers the entire bearing surface. The result: no freezing or sticking from fretting corrosion, so speeds can be changed quickly and easily at any time . . . regardless of the time lapse between changes. Maintenance is kept to a minimum and speed-range run through is eliminated.

- **1/2 thru 25 HP @ 1750 RPM**
- **Rugged Cast Iron Construction**
- **Precision Balanced**
- **Revolutionary Oil Lubrication Design**
- **Proven Reliability**

Selection

MODEL	HP RATING @			BELT	PITCH DIAMETER		DRIVE CHART PAGE NO.	
	3500	1750	1160		MIN.	MAX.		
GENERAL PURPOSE								
MS-58	V-F	3/4 - 1-1/2	1/2 - 3/4	1/3 - 1/2	1422V	2.10	5.75	D1-16
MS-72	V-F	1-1/2 - 2	1 - 1-1/2	1/2 - 1	1922V	2.41	7.25	D1-16
MS-77	V-F	1-1/2 - 3	1-1/2 - 3	1 - 2	2322V	2.58	7.75	D1-17
MS-77	V-V *	-	1-1/2 - 3	1 - 2	2322V	2.58	7.75	D1-17
MS-97	V-F	-	5 - 7-1/2	3 - 5	2926V	3.25	9.75	D1-18
MS-97	V-V *	-	5 - 10	3 - 5	2926V	3.25	9.75	D1-18
MS-127	V-F	-	7-1/2 - 15	5 - 10	4430V	4.25	12.75	D1-19
MS-127	V-V *	-	15 - 25	7-1/2 - 15	4430V	4.25	12.75	D1-19
OTHERS								
MS-975-S	V-V *	-	15 - 20	7-1/2 - 10	3230HV	4.70	9.40	D1-20
MS-100W	V-V *	-	15	7-1/2 - 10	4430V	5.00	10.00	D1-20
• MS-127W-HD	V-V *	-	15 - 20	7-1/2 - 10	4430V	4.25	12.75	D1-19

Horsepower ratings are based on constant torque and are shown for maximum pitch diameters.

Horsepower ratings at other pitch diameters reduce in proportion to the driven speed.

* Angled motor base required (ref. page D1-22).

• For heavy duty reversing application.

STOCK BORE SIZES

MODEL	5/8	3/4	7/8	1	1-1/8	1-1/4	1-3/8	1-5/8	1-7/8	28MM	MAX. BORE
MS-58	X	X	-	-	-	-	-	-	-	-	1-1/8
MS-72	X	X	X	X	-	-	-	-	-	-	1-1/8
MS-77	-	X	X	X	X	-	-	-	-	-	1-1/8
* MS-97	-	-	-	X	X	X	X	-	-	X	1-3/8
* MS-127	-	-	-	-	-	-	X	X	X	-	1-7/8
MS-975-S	-	-	-	-	-	-	-	X	-	-	1-7/8
MS-100W	-	-	-	-	-	-	-	X	-	-	1-7/8
* MS-127W-HD	-	-	-	-	-	-	-	X	-	-	1-7/8

* Clamp hub style.

ORDERING EXAMPLE: MS-58 x 5/8

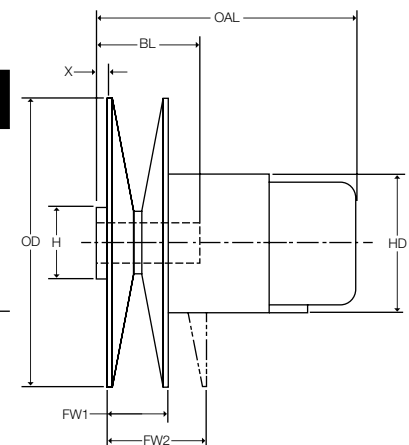

MS SHEAVE DIMENSIONS

MODEL	O.D.	H	HD	O.A.L.	B.L.	X	F.W.1	F.W.2	WT. LBS.
MS-58	6	1-7/8	3-7/8	5-1/16	2-5/8	5/16	1-1/16	1-13/16	10
MS-72	7-1/2	1-7/8	3-7/8	5-1/4	2-3/4	5/16	1-7/16	2-3/8	12
MS-77	8	2	3-7/8	5-7/16	2-7/8	5/16	1-11/16	2-3/4	13
MS-97	10	4	4-3/4	7-15/16	4-1/8	5/8	2-1/16	3-9/16	28
MS-127	13	4	6	9-3/16	5-1/4	1/2	3	5-1/4	53
MS-975-S	9-3/4	0	6	7-5/16	3-13/16	0	2-1/4	3-1/2	36
MS-100W	10-1/4	0	6	7-15/16	4	-9/16	3	4-5/16	37
MS-127W-HD	13	4	6	9-3/16	5-1/4	1/2	3	5-1/4	58

For optional Sight-Lube lubrication system, refer to D1-23.

Selection Charts

MS-58 V-FLAT OPERATION

DRIVEN SPEEDS			PRODUCT NUMBER	STRAIGHT FACE COMPANION PULLEY	CENTER DISTANCE IN INCHES AT MAXIMUM AND MINIMUM SPEED								
3500 RPM Motor	1750 RPM Motor	1160 RPM Motor			VARIABLE SPEED V-BELT NUMBER								
					1422V 330	1422V 360	1422V 420	1422V 480	1422V 540	1422V 600	1422V 660	1422V 720	1422V 780
3135	1567	1039	62S	6 x 2-SH	6.9	8.4	11.4	14.4	17.4	20.4	23.4	26.4	29.4
1145	572	379			9.7	11.2	14.3	17.3	20.3	23.3	26.3	29.4	32.4
2712	1356	899	72S	7 x 2-SH	-	7.6	10.6	13.6	16.6	19.6	22.6	25.6	28.6
991	495	328			-	10.3	13.4	16.4	19.5	22.5	25.5	28.5	31.5
2390	1195	792	82S	8 x 2-SH	-	-	9.7	12.8	15.8	18.8	21.8	24.8	27.8
873	436	289			-	-	12.4	15.5	18.6	21.6	24.7	27.7	30.7
2136	1068	708	92S	9 x 2-SH	-	-	8.9	11.9	14.9	17.9	21.0	24.0	27.0
780	390	259			-	-	11.5	14.6	17.7	20.7	23.8	26.8	29.8
1931	966	640	102S	10 x 2-SH	-	-	-	11.0	14.1	17.1	20.1	23.1	26.2
705	353	234			-	-	-	13.6	16.8	19.8	22.9	25.9	29.0
1620	810	537	122S	12 x 2-SH	-	-	-	-	12.2	15.3	18.4	21.4	24.5
592	296	196			-	-	-	-	14.8	18.0	21.1	24.2	27.2
1396	698	463	142S	14 x 2-SDS	-	-	-	-	10.2	13.4	16.6	19.6	22.7
510	255	169			-	-	-	-	12.6	15.9	19.1	22.3	25.4
1226	613	406	162S	16 x 2-SDS	-	-	-	-	-	11.3	14.6	17.7	20.9
448	224	148			-	-	-	-	-	-	13.6	17.0	20.3

MS-72 V-FLAT OPERATION

DRIVEN SPEEDS			PRODUCT NUMBER	STRAIGHT FACE COMPANION PULLEY	CENTER DISTANCE IN INCHES AT MAXIMUM AND MINIMUM SPEEDS									
3500 RPM Motor	1750 RPM Motor	1160 RPM Motor			VARIABLE SPEED V-BELT NUMBER									
					1922V 363	1922V 403	1922V 426	1922V 454	1922V 484	1922V 544	1922V 604	1922V 666	1922V 726	1922V 756
3893	1947	1290	62S	6 x 2-SH	7.3	9.3	10.5	11.9	13.4	16.4	19.4	22.5	25.5	27.0
1298	649	430			10.9	13.0	14.1	15.5	17.1	20.1	23.1	26.2	29.2	30.7
3375	1688	1119	72S	7 x 2-SH	-	8.5	9.7	11.1	12.6	15.6	18.6	21.7	24.7	26.2
1125	563	373			-	12.1	13.2	14.7	16.2	19.2	22.2	25.4	28.4	29.9
2979	1489	987	82S	8 x 2-SH	-	-	8.9	10.3	11.8	14.8	17.8	20.9	23.9	25.4
993	496	329			-	-	12.3	13.8	15.3	18.3	21.4	24.5	27.5	29.0
2666	1333	884	92S	9 x 2-SH	-	-	-	9.5	11.0	14.0	17.0	20.1	23.1	24.6
889	444	295			-	-	-	12.8	14.4	17.5	20.5	23.7	26.7	28.2
2413	1206	800	102S	10 x 2-SH	-	-	-	-	10.1	13.1	16.2	19.3	22.3	23.8
804	402	267			-	-	-	-	13.4	16.5	19.6	22.8	25.8	27.3
2027	1014	672	122S	12 x 2-SH	-	-	-	-	-	11.4	14.4	17.6	20.6	22.1
676	338	224			-	-	-	-	-	14.6	17.7	20.9	24.0	25.6
1748	874	579	142S	14 x 2-SDS	-	-	-	-	-	-	12.6	15.8	18.9	20.3
583	291	193			-	-	-	-	-	-	-	15.7	19.0	22.2
1536	768	509	162S	16 x 2-SDS	-	-	-	-	-	-	-	13.9	17.0	18.5
512	256	170			-	-	-	-	-	-	-	-	16.9	20.2

Refer to table on page D1-52 for additional belts available.

Selection Charts

MS-77 V-FLAT OPERATION

DRIVEN SPEEDS			PRODUCT NUMBER	STRAIGHT FACE COMPANION PULLEY	CENTER DISTANCE IN INCHES AT MAXIMUM AND MINIMUM SPEEDS									
3500 RPM Motor	1750 RPM Motor	1160 RPM Motor			VARIABLE SPEED V-BELT NUMBER									
					2322V 421	2322V 441	2322V 481	2322V 521	2322V 541	2322V 601	2322V 661	2322V 721	2322V 801	2322V 1001
3145	1572	1042	8234S	8 x 2-3/4-SD	8.2	9.3	11.4	13.2	14.4	17.3	20.3	23.4	27.4	37.4
1048	524	347			11.9	13.0	15.1	16.9	18.2	21.2	24.2	27.2	31.2	41.3
2818	1409	934	9234S	9 x 2-3/4-SD	-	-	10.6	12.4	13.6	16.6	19.6	22.6	26.6	36.7
939	470	311			-	-	14.3	16.0	17.4	20.4	23.4	26.4	30.4	40.5
2553	1276	846	10234S	10 x 2-3/4-SD	-	-	9.7	11.5	12.7	15.7	18.6	21.7	25.6	35.7
851	425	282			-	-	13.3	15.1	16.4	19.5	22.5	25.6	29.5	39.6
2333	1167	773	11234S	11 x 2-3/4-SD	-	-	-	10.6	11.8	14.8	17.8	20.9	24.9	35.0
778	389	258			-	-	-	14.2	15.5	18.5	21.6	24.6	28.7	38.8
2148	1074	712	12234S	12 x 2-3/4-SD	-	-	-	-	10.9	14.0	17.0	20.1	24.2	34.2
716	358	237			-	-	-	-	14.5	17.5	20.6	23.8	27.8	37.9
1855	927	615	14234S	14 x 2-3/4-SF	-	-	-	-	-	12.2	15.3	18.4	22.4	32.5
618	309	205			-	-	-	-	-	15.6	18.9	21.9	26.0	36.2
1631	816	541	16234S	16 x 2-3/4-SF	-	-	-	-	-	-	13.5	16.6	20.6	30.8
544	272	180			-	-	-	-	-	-	16.6	19.9	24.0	34.4
1456	728	483	18234S	18 x 2-3/4-SF	-	-	-	-	-	-	-	14.5	18.6	29.0
485	243	161			-	-	-	-	-	-	-	17.7	22.1	32.6
1315	658	436	20234S	20 x 2-3/4-SF	-	-	-	-	-	-	-	-	16.7	27.2
438	219	145			-	-	-	-	-	-	-	-	19.9	30.7

MS-77 V-V OPERATION

DRIVEN SPEEDS		PRODUCT NUMBER	GROOVED COMPANION PULLEY	CENTER DISTANCE IN INCHES AT MAXIMUM AND MINIMUM SPEEDS									
1750 RPM Motor	1160 RPM Motor			VARIABLE SPEED V-BELT NUMBER									
				2322V 421	2322V 441	2322V 481	2322V 521	2322V 541	2322V 601	2322V 661	2322V 721	2322V 801	2322V 1001
2055	1362	661P	6.6 x 1P-SK	9.7	10.7	12.7	14.7	15.7	18.7	21.7	24.7	28.7	38.7
685	454			13.6	14.6	15.6	18.6	19.6	22.6	25.6	28.6	32.7	42.7
1785	1183	761P	7.6 x 1P-SK	8.9	9.9	11.9	13.9	14.9	17.9	20.9	23.9	27.9	37.9
595	394			12.7	13.7	15.7	17.8	18.8	21.8	24.8	27.8	31.8	41.9
1577	1045	861P	8.6 x 1P-SK	-	9.1	11.1	13.1	14.1	17.1	20.1	23.1	27.1	37.1
526	348			-	12.8	14.9	16.9	17.9	20.9	24.0	27.0	31.0	41.0
1413	936	961P	9.6 x 1P-SK	-	-	10.3	12.3	13.3	16.3	19.3	22.3	26.3	36.3
471	312			-	-	13.9	16.0	17.0	20.1	23.1	26.3	30.2	40.2
1262	836	1081P	10.8 x 1P-SK	-	-	-	11.4	12.4	15.4	18.5	21.5	25.5	35.5
420	278			-	-	-	15.0	16.0	19.1	22.2	25.2	29.3	39.4
1154	765	1181P	11.8 x 1P-SK	-	-	-	10.5	11.6	14.6	17.6	20.6	24.6	34.7
384	255			-	-	-	14.0	15.0	18.2	21.3	24.3	28.4	38.5
986	654	1381P	13.8 x 1P-SK	-	-	-	-	-	12.8	15.9	18.9	23.0	33.0
328	218			-	-	-	-	-	16.2	19.4	22.5	26.6	36.8
861	571	1581P	15.8 x 1P-SK	-	-	-	-	-	-	14.0	17.1	21.2	31.3
287	190			-	-	-	-	-	-	17.4	20.6	24.7	35.0
764	506	1781P	17.8 x 1P-SK	-	-	-	-	-	-	-	15.2	19.3	29.6
254	169			-	-	-	-	-	-	-	18.5	22.8	33.2

Refer to table on page D1-53 for additional belts available.

Selection Charts

MS-97 V-FLAT OPERATION

DRIVEN SPEEDS		PRODUCT NUMBER	STRAIGHT FACE COMPANION PULLEY	CENTER DISTANCE IN INCHES AT MAXIMUM AND MINIMUM SPEEDS							
1750 RPM Motor	1160 RPM Motor			VARIABLE SPEED V-BELT NUMBER							
				2926V 574	2926V 606	2926V 646	2926V 686	2926V 726	2926V 834	2926V 906	2926V 1006
1595	1057	10234S	†10 x 2-3/4-SD	12.5	14.3	16.3	18.4	20.3	25.6	29.4	34.3
532	352			17.2	19.0	21.0	23.0	25.0	30.4	34.2	39.2
1458	967	11234S	†11 x 2-3/4-SD	11.3	13.3	15.3	17.4	19.4	24.6	28.4	33.4
486	322			16.3	18.0	20.1	22.2	24.2	29.6	33.3	38.3
1344	841	12234S	12 x 2-3/4-SD	-	12.5	14.5	16.6	18.6	23.9	27.6	32.6
448	297			-	17.2	19.2	21.3	23.3	28.8	32.4	37.5
1161	769	14234S	14 x 2-3/4-SD	-	-	12.9	14.9	16.9	22.2	26.0	31.0
387	256			-	-	17.3	19.4	21.4	27.0	30.7	35.7
1022	677	16234S	16 x 2-3/4-SF	-	-	-	-	15.2	20.6	24.3	29.4
341	226			-	-	-	-	19.4	25.0	28.9	34.0
912	605	18234S	18 x 2-3/4-SF	-	-	-	-	-	18.8	22.7	27.7
304	202			-	-	-	-	-	23.2	27.0	32.0
824	546	20234S	20 x 2-3/4-SF	-	-	-	-	-	16.7	20.7	25.7
275	182			-	-	-	-	-	20.9	24.9	30.2
691	458	24414S	24 x 4-1/4-SF	-	-	-	-	-	-	-	22.1
230	153			-	-	-	-	-	-	-	26.2

† This companion pulley not recommended for 7-1/2 HP at 1750 RPM or 5 HP at 1160 RPM applications.

MS-97 V-V OPERATION

DRIVEN SPEEDS		PRODUCT NUMBER	GROOVED COMPANION PULLEY	CENTER DISTANCE IN INCHES AT MAXIMUM AND MINIMUM SPEEDS							
1750 RPM Motor	1160 RPM Motor			VARIABLE SPEED V-BELT NUMBER							
				2926V 574	2926V 606	2926V 646	2926V 686	2926V 726	2926V 834	2926V 906	2926V 1006
2245	1488	761T	7.6 x 1T-SK	15.03	16.63	18.63	20.66	22.66	28.07	31.67	36.67
748	496			20.07	21.68	23.68	25.68	27.68	33.12	36.73	41.73
1984	1315	861T	8.6 x 1T-SK	14.29	15.89	17.89	19.89	21.89	27.29	30.89	35.89
661	438			19.20	20.83	22.85	24.85	26.85	32.29	35.90	40.90
1777	1178	961T	9.6 x 1T-SK	13.51	15.11	17.11	19.11	21.11	26.51	30.11	35.11
592	392			18.34	19.96	21.96	24.01	26.01	31.46	35.06	40.09
1609	1067	1061T	10.6 x 1T-SK	12.72	14.32	16.32	18.32	20.32	25.72	29.32	34.32
536	355			17.43	19.08	21.11	23.13	25.17	30.61	34.23	39.26
1470	975	1161T	11.6 x 1T-SK	11.89	13.49	15.49	17.52	19.52	24.93	28.53	33.53
490	325			16.49	18.14	20.19	22.24	24.29	29.74	33.39	38.42
1254	831	1361T	13.6 x 1T-SK	-	-	13.82	15.86	17.87	23.27	26.91	31.92
418	277			-	-	18.32	20.42	22.47	27.97	31.65	36.71
1094	725	1561T	15.6 x 1T-SK	-	-	-	14.10	16.14	21.60	25.24	30.25
364	242			-	-	-	18.45	20.55	26.15	29.85	34.95
969	642	1761T	17.6 X 1T-SK	-	-	-	-	-	19.83	23.48	28.56
323	214			-	-	-	-	-	24.27	28.01	33.13
870	577	1961T	19.6 x 1T-SK	-	-	-	-	-	17.96	21.70	26.81
290	192			-	-	-	-	-	22.25	26.06	31.29

Refer to table on page D1-53 for additional belts available.

MS-127 V-FLAT OPERATION

DRIVEN SPEEDS		PRODUCT NUMBER	STRAIGHT FACE COMPANION PULLEY	CENTER DISTANCE IN INCHES AT MAXIMUM AND MINIMUM SPEEDS													
1750 RPM Motor	1160 RPM Motor			VARIABLE SPEED V-BELT NUMBER													
				4430V 690	4430V 700	4430V 730	4430V 740	4430V 790	4430V 850	4430V 910	4430V 970	4430V 1030	4430V 1090	4430V 1150	4430V 1320	4430V 1460	4430V 1610
1728	1145	12414S	†12 x 4-1/4-SF	14.3	14.7	16.3	16.8	19.2	22.3	25.3	28.4	31.4	34.2	37.4	45.7	52.3	60.6
576	382			20.6	21.2	22.7	23.2	25.7	28.8	31.7	34.8	37.8	40.8	43.9	52.4	58.8	67.3
1496	992	14414S	†14 x 4-1/4-SF	-	-	14.9	15.4	17.8	20.7	23.8	26.9	29.8	32.8	35.7	44.5	50.7	59.2
499	331			-	-	20.9	21.4	23.9	27.0	30.0	33.2	36.0	39.2	42.2	50.8	57.0	65.5
1319	875	16414S	†16 x 4-1/4-SF	-	-	-	-	16.2	19.2	22.2	25.4	28.4	31.2	34.1	42.8	49.2	57.9
440	292			-	-	-	-	22.0	25.1	28.3	31.3	34.4	37.4	40.4	49.1	55.3	63.9
1180	782	18414S	18 x 4-1/4-SF	-	-	-	-	-	17.2	20.3	23.3	26.5	29.3	32.4	41.0	47.3	56.0
393	261			-	-	-	-	-	23.1	26.3	29.4	32.5	35.6	38.6	47.2	53.6	61.9
1067	707	20414S	20 x 4-1/4-SF	-	-	-	-	-	-	18.6	21.7	24.8	27.7	30.6	39.4	45.7	54.3
356	236			-	-	-	-	-	-	24.7	27.7	30.8	33.6	36.9	45.5	51.8	60.5
896	594	24414S	24 x 4-1/4-SF	-	-	-	-	-	-	-	-	21.4	24.2	27.3	36.0	42.4	51.1
299	198			-	-	-	-	-	-	-	-	-	26.4	29.7	33.0	41.8	48.1

† This companion pulley not recommended for 15 HP at 1750 RPM or 10 HP at 1160 RPM applications.

MS-127 & MS-127W-HD V-V OPERATION

DRIVEN SPEEDS		PRODUCT NUMBER	GROOVED COMPANION PULLEY	CENTER DISTANCE IN INCHES AT MAXIMUM AND MINIMUM SPEEDS													
1750 RPM Motor	1160 RPM Motor			VARIABLE SPEED V-BELT NUMBER													
				4430V 690	4430V 700	4430V 730	4430V 740	4430V 790	4430V 850	4430V 910	4430V 970	4430V 1030	4430V 1090	4430V 1150	4430V 1320	4430V 1460	4430V 1610
2231	1479	1001W	10.0 x 1W-SF	16.5	17.0	18.5	19.0	21.5	24.5	27.5	30.5	33.5	36.5	39.5	48.0	55.3	62.7
744	493			23.0	23.5	25.0	25.5	28.0	31.0	34.1	37.1	40.1	43.1	46.1	54.6	61.8	69.2
2028	1344	1101W	11.0 x 1W-SF	15.7	16.2	17.7	18.2	20.7	23.7	26.7	29.7	32.7	35.7	38.7	47.2	54.6	62.0
676	448			22.1	22.6	24.1	24.7	27.2	30.2	33.2	36.2	39.2	42.3	45.3	53.8	60.9	68.4
1859	1233	1201W	12.0 x 1W-SF	14.9	15.4	16.9	17.4	19.9	22.9	25.9	28.4	31.9	34.9	37.9	46.4	53.7	61.2
620	411			20.9	21.4	22.9	23.4	25.9	30.0	32.0	35.0	38.0	41.1	44.1	52.6	60.2	67.8
1716	1138	1301W	13.0 x 1W-SF	14.2	14.7	16.1	16.7	19.1	22.1	25.2	28.2	31.1	34.2	37.2	45.7	53.0	60.5
572	379			20.4	20.9	22.4	22.9	25.4	28.5	31.5	34.6	37.6	40.6	43.6	52.1	59.3	66.8
1594	1056	1401W	14.0 x 1W-SF	-	-	15.3	15.9	18.3	21.3	24.4	27.4	30.4	33.4	36.4	44.9	52.0	59.6
531	352			-	-	21.5	22.0	24.5	27.6	30.7	33.7	36.7	39.7	42.8	51.3	58.5	66.0
1488	986	1501W	15.0 x 1W-SF	-	-	-	15.0	17.5	20.5	23.6	26.6	29.6	32.6	35.6	44.1	51.3	58.8
496	329			-	-	-	21.1	23.6	26.7	29.8	32.8	35.8	38.9	41.9	50.5	57.5	65.0
1394	924	1601W	16.0 x 1W-SF	-	-	-	-	16.7	19.7	22.7	25.8	28.7	31.8	34.8	43.3	50.8	58.0
465	308			-	-	-	-	22.7	25.8	28.9	31.9	35.0	38.0	41.1	49.6	56.8	64.4
1240	822	1801W	18.0 x 1W-SF	-	-	-	-	-	18.0	21.1	24.1	27.1	30.1	33.1	41.6	48.9	56.5
413	274			-	-	-	-	-	23.9	27.0	30.1	33.2	36.3	39.3	47.9	54.9	62.5
1116	740	2001W	20.0 x 1W-SF	-	-	-	-	-	-	19.3	22.4	25.4	28.4	31.5	40.0	47.5	54.9
372	247			-	-	-	-	-	-	25.1	28.2	31.3	34.4	37.5	46.2	53.4	60.9
1014	672	2201W	22.0 x 1W-SF	-	-	-	-	-	-	-	20.6	23.6	26.7	29.7	38.3	45.5	53.0
338	224			-	-	-	-	-	-	-	-	26.3	29.4	32.6	35.7	44.4	51.5
930	616	2401W	24.0 x 1W-SF	-	-	-	-	-	-	-	-	21.8	24.9	28.0	36.6	43.7	51.2
310	205			-	-	-	-	-	-	-	-	-	27.4	30.6	33.7	42.5	49.8
796	528	2801W	28.0 x 1W-E	-	-	-	-	-	-	-	-	-	-	24.3	33.2	40.3	47.9
265	176			-	-	-	-	-	-	-	-	-	-	-	29.8	38.9	46.2

Refer to table on page D1-53 for additional belts available.

Selection Charts

MS-975-S V-V OPERATION

DRIVEN SPEEDS		PRODUCT NUMBER	GROOVED COMPANION PULLEY	CENTER DISTANCE IN INCHES AT MAXIMUM AND MINIMUM SPEEDS																
1750 RPM Motor	1160 RPM Motor			VARIABLE SPEED V-BELT NUMBER																
				3230 HV 528	3230 HV 546	3230 HV 553	3230 HV 570	3230 HV 585	3230 HV 603	3230 HV 613	3230 HV 626	3230 HV 644	3230 HV 670	3230 HV 685	3230 HV 723	3230 HV 821	3230 HV 856	3230 HV 931	3230 HV 960	3230 HV 1060
1731	1147	951S	9.5 x 1S-SF	11.6	12.5	12.8	13.7	14.4	15.3	15.8	16.5	17.4	18.7	19.4	21.3	26.2	28.0	31.7	33.2	38.2
866	574			15.1	16.0	16.3	17.2	17.9	18.8	19.3	20.0	20.9	22.2	23.0	24.9	29.8	31.6	35.3	36.8	41.8
1645	1090	1001S	10.0 x 1S-SF	11.2	12.1	12.4	13.3	14.0	14.9	15.4	16.1	17.0	18.3	19.0	20.9	25.8	27.6	31.3	32.8	37.8
823	546			14.6	15.5	15.9	16.7	17.5	18.4	18.9	19.6	20.5	21.8	22.5	24.5	29.4	31.1	34.9	36.4	41.4
1495	991	1101S	11.0 x 1S-SF	-	11.3	11.6	12.5	13.2	14.1	14.6	15.3	16.2	17.5	18.2	20.1	25.0	26.8	30.5	32.0	37.0
748	496			-	14.6	15.0	15.9	16.6	17.5	18.0	18.7	19.6	20.9	21.7	23.6	28.5	30.3	34.1	35.5	40.1
1370	908	1201S	12.0 x 1S-SF	-	-	-	11.6	12.4	13.3	13.8	14.4	15.4	16.6	17.4	19.3	24.2	26.0	29.7	31.2	36.2
686	455			-	-	-	14.9	15.7	16.6	17.1	17.8	18.7	20.1	28.0	22.7	27.7	29.5	33.2	34.7	39.7
1265	838	1301S	13.0 x 1S-SF	-	-	-	-	-	12.4	12.9	13.6	14.5	15.8	16.6	18.5	23.4	25.1	28.9	30.4	35.4
633	420			-	-	-	-	-	15.7	16.2	16.9	17.8	19.1	19.9	21.9	26.8	28.6	32.4	33.8	38.9
1175	778	1401S	14.0 x 1S-SF	-	-	-	-	-	-	12.1	12.7	13.6	14.9	15.7	17.6	22.6	24.3	28.1	29.5	34.5
588	390			-	-	-	-	-	-	-	15.3	15.9	16.9	18.2	19.0	20.9	25.9	27.7	31.5	33.0
1096	726	1501S	15.0 x 1S-SF	-	-	-	-	-	-	-	-	12.7	14.1	14.8	16.8	21.7	23.5	27.2	28.7	33.7
549	364			-	-	-	-	-	-	-	-	-	15.9	17.3	18.0	20.0	25.0	26.8	30.6	32.1
1028	682	1601S	16.0 x 1S-SF	-	-	-	-	-	-	-	-	-	-	13.9	15.9	20.8	22.6	26.4	27.9	32.9
514	341			-	-	-	-	-	-	-	-	-	-	-	17.1	19.1	24.1	25.9	29.8	31.2
914	606	1801S	18.0 x 1S-SF	-	-	-	-	-	-	-	-	-	-	-	13.9	19.0	20.8	24.7	26.1	31.2
457	303			-	-	-	-	-	-	-	-	-	-	-	-	17.0	22.2	24.0	27.9	29.4
822	546	2001S	20.0 x 1S-SF	-	-	-	-	-	-	-	-	-	-	-	...	17.1	19.0	22.8	24.3	29.4
411	273			-	-	-	-	-	-	-	-	-	-	-	-	...	20.2	22.0	26.0	27.5

MS100W V-V OPERATION

DRIVEN SPEEDS		PRODUCT NUMBER	GROOVED COMPANION PULLEY	CENTER DISTANCE IN INCHES AT MAXIMUM AND MINIMUM SPEEDS														
1750 RPM Motor	1160 RPM Motor			VARIABLE SPEED V-BELT NUMBER														
				4430V 530	4430V 555	4430V 578	4430V 610	4430V 630	4430V 660	4430V 690	4430V 730	4430V 790	4430V 850	4430V 910	4430V 970	4430V 1090	4430V 1320	4430V 1610
2188	1450	801W	8.0 x 1W-SF	12.1	13.5	14.7	16.2	17.2	18.7	20.2	22.2	25.2	28.2	31.2	34.2	40.2	51.7	66.8
1094	725			16.0	17.4	18.6	20.1	21.1	22.6	24.1	26.1	29.1	32.1	35.1	38.1	44.1	55.6	70.7
2059	1365	851W	8.5 x 1W-SF	11.7	13.1	14.3	15.8	16.8	18.3	19.8	21.8	24.8	27.8	30.8	33.8	39.8	51.3	66.5
1029	682			15.6	16.9	18.2	19.7	20.7	22.2	23.7	25.7	28.7	31.7	34.7	37.7	43.7	55.2	70.3
1944	1289	901W	9.0 x 1W-SF	11.3	12.7	13.9	15.4	16.4	17.9	19.4	21.4	24.4	27.4	30.4	33.5	39.5	51.0	66.1
972	644			15.1	16.5	17.8	19.3	20.3	21.8	23.3	25.3	28.3	31.3	34.3	37.3	43.3	54.8	69.9
1842	1221	951W	9.5 x 1W-SF	11.0	12.3	13.6	15.1	16.1	17.6	19.1	21.0	24.0	27.0	30.1	33.1	39.1	50.6	65.6
921	611			14.7	16.1	17.3	18.9	19.9	21.4	22.9	24.9	27.9	30.9	33.9	36.9	42.9	54.4	69.5
1750	1160	1001W	10.0 x 1W-SF	10.6	11.9	13.2	14.7	15.7	17.2	18.7	20.7	23.7	26.7	29.7	32.7	38.7	50.2	65.2
875	580			14.3	15.6	16.9	18.4	19.4	20.9	22.5	24.5	27.5	30.5	33.5	36.5	42.5	54.0	69.0
1591	1054	1101W	11.0 x 1W-SF	-	11.0	12.4	13.9	14.9	16.4	17.9	19.9	22.9	25.9	28.9	31.9	37.9	49.4	64.2
795	527			-	14.7	16.0	17.6	18.6	20.1	21.6	23.6	26.6	29.7	32.7	35.7	41.7	53.2	68.2
1458	967	1201W	12.0 x 1W-SF	-	-	11.6	13.1	14.1	15.6	17.1	19.1	22.1	25.1	28.1	31.1	37.1	48.6	63.5
729	483			-	-	15.1	16.7	17.7	19.2	20.7	22.7	25.8	28.8	31.8	34.8	40.9	52.4	67.4
1346	892	1301W	13.0 x 1W-SF	-	-	-	12.4	13.2	14.7	16.2	18.2	21.2	24.3	27.3	30.3	36.3	47.8	62.7
673	446			-	-	-	15.9	16.8	18.3	19.8	21.9	24.9	28.0	31.0	34.0	40.0	51.6	66.6
1250	828	1401W	14.0 x 1W-SF	-	-	-	-	12.5	13.9	15.4	17.4	20.4	23.4	26.5	29.5	35.5	47.0	62.1
625	414			-	-	-	-	16.0	17.3	18.9	21.0	24.0	27.1	30.1	33.2	39.2	50.8	65.8
1167	773	1501W	15.0 x 1W-SF	-	-	-	-	-	13.2	14.5	16.5	19.6	22.6	25.6	28.6	34.7	46.2	61.3
583	387			-	-	-	-	-	-	16.5	18.0	20.0	23.1	26.2	29.2	32.3	38.3	49.9
1094	725	1601W	16.0 x 1W-SF	-	-	-	-	-	-	13.8	15.7	18.7	21.7	24.8	27.8	33.8	45.4	60.5
547	363			-	-	-	-	-	-	17.1	19.1	22.2	25.3	28.3	31.4	37.5	49.1	64.0
972	644	1801W	18.0 x 1W-SF	-	-	-	-	-	-	-	-	16.9	20.0	23.0	26.1	32.1	48.7	58.9
486	322			-	-	-	-	-	-	-	-	-	-	19.2	24.4	26.5	29.6	35.7
875	580	2001W	20.0 x 1W-SF	-	-	-	-	-	-	-	-	-	18.1	21.2	24.3	30.4	42.0	57.1
438	290			-	-	-	-	-	-	-	-	-	-	21.4	24.6	27.7	33.9	45.6
795	527	2201W	22.0 x 1W-SF	-	-	-	-	-	-	-	-	-	17.2	19.3	22.4	28.6	40.3	55.5
398	264			-	-	-	-	-	-	-	-	-	-	19.3	22.6	25.8	32.0	43.9
729	483	2401W	24.0 x 1W-SF	-	-	-	-	-	-	-	-	-	-	-	20.5	26.8	38.5	53.7
365	242			-	-	-	-	-	-	-	-	-	...	-	-	23.7	30.1	42.0
625	414	2801W	28.0 x 1W-E	-	-	-	-	-	-	-	-	-	-	-	...	22.9	35.0	49.9
312	207			-	-	-	-	-	-	-	...	-	-	-	-	...	26.1	38.4

Refer to table on page D1—53 for additional belts available.

MS Single Flange Moving Drive Set-Up

Options

V-V Drive Set-up

On a v-groove to v-groove drive using a single flange moving sheave, it is necessary to angle mount the motor in order to keep the belt aligned. This is due to the fact that the belt is not only moving from max. to min. pitch it is also moving axially as it is being adjusted. The angle mount base compensates for this axial movement of the belt.

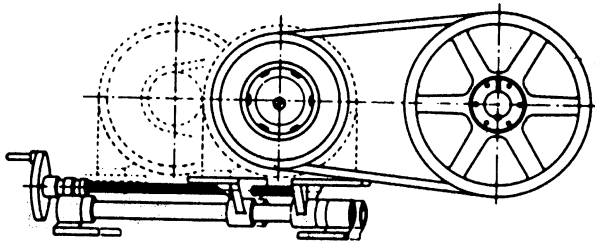
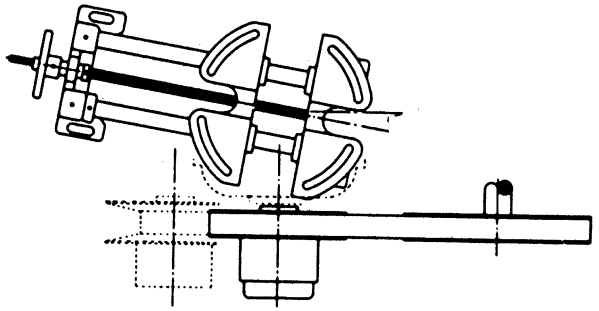

V-Flat Drive Set-up

On a v-groove to flat pulley drive using a single flange moving sheave, the movement of the base is perfectly perpendicular to the shafts. As the belt moves from max. to min. pitch on the variable it is also moving axially across the face of the flat pulley. In most cases the drive hp capacity is less on a v-flat than a v-v drive using the same spring-loaded sheave.

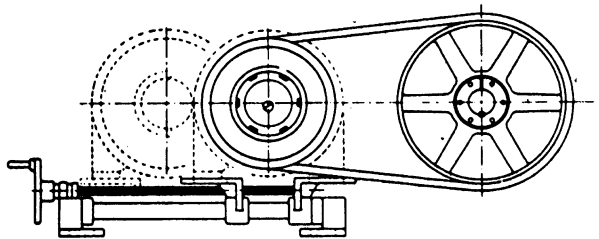
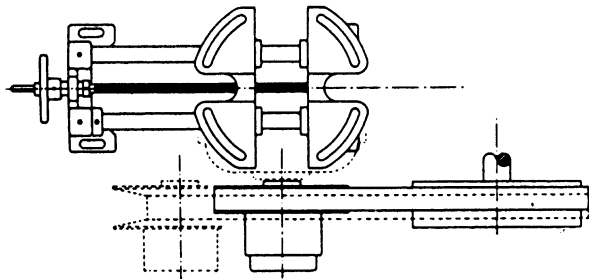

Angled Motor Case

Calculations

Because of the unique lubricating principle employed in the Wood's MS sheaves, they are constructed so that only a single flange is adjustable. When a straight face pulley is used as a companion, the belt will traverse across the face of the pulley as the pitch diameter of the MS is changed. However, in order to maintain correct belt alignment when running the MS sheave to a V-groove companion, the motor must be mounted on an angled base to compensate for the belt movement.

When an MC base is furnished, the motor mount holes are drilled in the sliding plate at the angle required by each specific application. When using an MBA motor base, slots are provided for offsetting the motor to any angle.

Angle to Offset Motor Base

To Find Offset Angle:

- Determine mean center distance.

$$\text{Mean C.D.} = \frac{\text{Max.} + \text{Min.}}{2}$$

- Find difference in center line elevation.
- Using appropriate table below with required elevation, read across until mean center is located; then read at bottom of table the offset angle. Interpolate for elevations or center distances not shown.

Example:
 Sheave MS-100-W
 C.D. Min. 18.0, Max. 22.0
 Elevation 7"
 Offset Angle – 9-1/2°

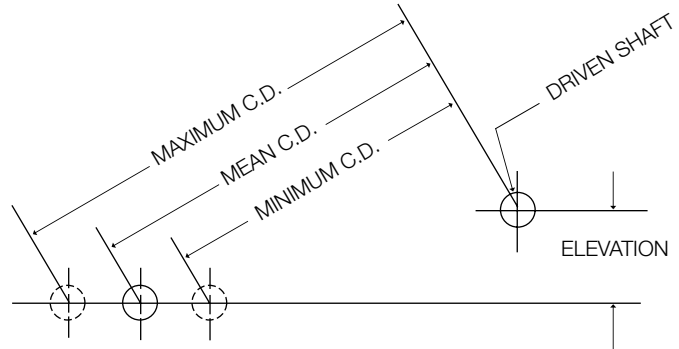

		MS-77								
Elevation – inches	3	Mean Center Distance – inches								9*
	4	Offset angle 7-1/2° for less than								9 12*
	5	3" elevation; all center								9 10 15*
	6	distances.								9 10 12 18*
	7									9 10 11 12 15 21*
	8									9 10 10 11 12 14 17 24*
	10									12 12 13 14 15 17 21 29*
	12									14 14 15 16 18 21 25 35*
14									16 17 18 19 21 24 29 41*	
16									18 19 20 22 24 27 33 47*	
Offset Angle		4°	4-1/2°	5°	5-1/2°	6°	6-1/2°	7°	7-1/2°	

		MS-97								
Elevation – inches	3	Mean Center Distance – inches								10*
	4	Offset angle 9° for less than								13*
	5	3" elevation; all center								11 16*
	6	distances.								11 13 19*
	7									11 13 16 22*
	8									11 12 13 15 18 25*
	10									12 13 14 15 16 18 22 32*
	12									15 15 16 18 20 22 27 38*
14									17 18 19 21 23 26 31 44*	
16									20 21 22 24 26 30 36 50*	
Offset Angle		5-1/2°	6°	6-1/2°	7°	7-1/2°	8	8-1/2°	9°	

		MS-100W MS-127 MS-975-S										
Elevation – inches	3	Mean Center Distance – inches										11* 19*
	4	Offset angle 10° for less than										12 15* 23*
	5	3" elevation; all center										11 14 19* 29*
	6	distances.										11 13 17 22* 35*
	7											11 13 15 20 26* 41*
	8											11 12 13 15 17 23 30* 47*
	10											12 12 13 14 15 16 18 21 28 37* 58*
	12											14 15 16 17 18 19 22 26 34 44*
14											17 17 18 19 21 23 25 30 40 50*	
16											19 20 21 22 24 26 29 34 46 57*	
Offset Angle		5-1/2°	6°	6-1/2°	7°	7-1/2°	8°	8-1/2°	9°	9-1/2°	9-3/4°	10°

* Mean center distances and larger.

Lubrication System

The Sight-Lube lubrication system is available for Wood's MS and MCS motion control variable speed sheaves.

This system permits split-second checking of the oil level in the sheave's reservoir. The sight gauge can be mounted at any convenient location above the drive.

The advantages that the Sight-Lube lubrication offers combined with the unique features of Wood's exclusive motion control sheave oil lubrication system provide outstanding user benefits. While lubrication checks are required only infrequently with Wood's motion control variable speed drives, downtime for such routine maintenance is nonexistent.

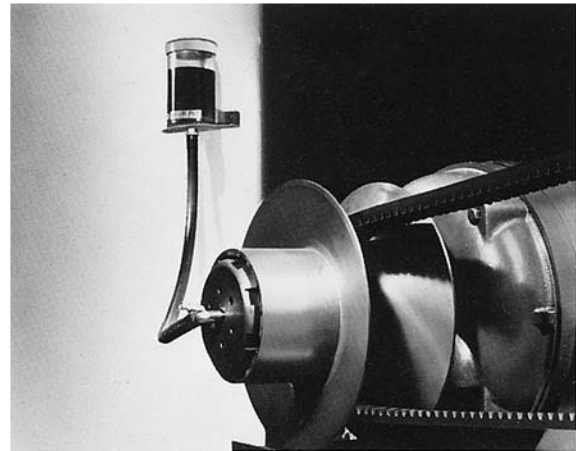

Reservoir Kit

The ADAPTER KIT, shown at right, consisting of the sheave adapter, gasket and three cap screws is available to fit most existing Wood's oil lubricated variable speed sheaves, and can also be supplied for new units.

The RESERVOIR KIT, at left, is included with all Sight-Lube systems unless specified otherwise. The reservoir is of clear polycarbonate plastic permanently attached to a durable plastic bracket with holes for mounting to any vertical or horizontal surface. This kit also includes a 36-inch section of hose with the necessary clamps for connecting to the rotating joint on the sheave.



Sheave Adapter Kit

How to Order the Sight-Lube Lubrication System

Sight-Lube Kits for installation on existing Wood's motion control variable speed sheaves are available as listed in chart below. Determine the part number of the sheave and from the chart select the proper Sight-Lube Kit number. Example: If the Sight-Lube System is required for an existing MS-97 sheave, order one SL2K Adapter Kit and one SR2K Reservoir Kit.

Kits Available

For Use With Variable Sheave No.	Adapter Kit Kit No.	Reservoir Kit Kit No.
MS-97	SL2K	SR2K
MS-127, MS-100W, MS-975-S	SL3K	SR2K
MCS-All sizes except 14Y & 15Y	SL3K	SR2K
MCS 14Y & 15Y	SL4K	SR2K

Features

Roto-Cone® variable speed sheaves and drives allow smooth, infinitely-variable speed changes without stopping the drive motor. Positive rack and pinion design provides equal and opposite lateral movement of both discs, so belts always travel on a fixed center line. Ratings to 30 HP at 1750 RPM. Needs only periodic lubrication. Positive pulling power, precision balanced, proven reliability.



Features

- **V to V Operating Principle**

The exclusive rack and gear arrangement incorporated into the design of the ROTO-CONE® Motor Sheave imparts a positive and equal linear movement to each pulley disc. The movement of one disc is opposite to that of the other, thereby causing the belt to travel on a fixed center line. This fixed center line allows driving to a “V” groove companion sheave which need be only slightly wider than the belt. The “V” to “V” principle makes for more efficient power transmission, straight line adjustment of the motor and sheave, longer belt life, vibrationless drive, and eliminates twisting and curling of the belt when changing speeds.

- **Lubrication**

Close-Grooving grease groove in the bore of the inner disc distributes grease throughout the entire hub length. Sheaves, from RC80 through RC1330 have additional grease fittings and passages to assure thorough lubrication throughout the pulley length. These features combine to practically eliminate fretting corrosion and sticking discs.

- **Bores**

To ensure a true shaft mounting, all ROTO-CONE® Sheave shafts are precision bored with overall tolerances of .0005.”

- **1/2 thru 30 HP**
- **V-to-V Drive**
- **Operates in Vertical or Horizontal Position**
- **Exclusive Rack and Pinion Design**
- **Proven Reliability**
- **Conventional and Compound Drives**
- **Rugged Cast Iron Construction**

Selection

MODEL	HP RATING @			BELT	PITCH DIA.		DRIVE CHART PAGE NO.
	3500	1750	1160		MIN.	MAX.	
RC55	1	1/2	1/3	1422V	1.75	5.25	D1-26
RC60	1-1/2	3/4	1/2	1922V	1.92	5.75	D1-26
RC75	-	1 - 1-1/2	7/8 - 1	1922V	2.42	7.25	D1-27
RC80	-	1-1/2 - 3	1 - 2	2322V	2.58	7.75	D1-27
RC105	-	1-1/2 - 3	1 - 2	2926V	2.58	10.38	D1-28
RC100	-	3 - 5	1-1/2 - 3	2926V	3.25	9.75	D1-28
RC1315	-	7-1/2 -15	5 - 10	4430V	4.25	12.75	D1-29
RC1330	-	15-30	10 - 20	4430V	4.63	12.75	D1-29

Horsepower ratings are based on constant torque and are shown for maximum pitch diameter.
Horsepower ratings at other pitch diameters reduce in proportion to the driven speed.

STOCK BORE SIZES AND BORE LENGTHS (BL)

MODEL	BORE SIZE IN INCHES										MAX. BORE
	1/2	5/8	3/4	7/8	1	1-1/8	1-1/4	1-3/8	1-5/8	1-7/8	
	BORE LENGTH IN INCHES										
RC55	1-3/4 *	1-3/4	-	-	-	-	-	-	-	-	5/8
RC60	-	1-7/8	1-7/8	-	-	-	-	-	-	-	3/4
RC75	-	1-7/8	2-1/4	2-5/16	-	-	-	-	-	-	7/8
RC80	-	-	2-1/4	2-5/8	3	3-3/8	-	-	-	-	1-1/8
RC105	-	-	2-1/4	2-5/8	3	3-3/8	-	-	-	-	1-1/8
RC100	-	-	-	-	3	3-3/8	3-3/4	-	-	-	1-1/4
RC1315	-	-	-	-	-	3-3/8	3-3/4	4-1/8	4-7/8	-	1-15/16
RC1330	-	-	-	-	-	-	3-3/4	4-1/8	4-7/8	5-3/8	1-15/16

* No keyseat.

ORDERING EXAMPLE: RC60 x 5/8

ROTO-CONE SHEAVE DIMENSIONS

MODEL	O.D.	H	O.A.L.	X	F.W. MAX	WT. LBS.
RC55	5-1/2	2-1/8	5-1/8	1	1-13/16	6
RC60	6	2-1/8	6-1/16	15/16	2-1/4	7
RC75	7-1/2	2-1/2	7-1/2	1-1/4	2-5/8	13.5
RC80	8	3	8-1/2	1-7/16	2-3/4	17
RC105	10-5/8	3	8-1/2	1-13/16	3-1/4	24
RC100	10	3-7/8	10-13/16	2-1/16	3-7/8	34
RC1315	13	5	12-7/8	2-1/4	5-3/8	59
RC1330	13	6-1/4	12-3/8	2-1/2	5-5/8	70

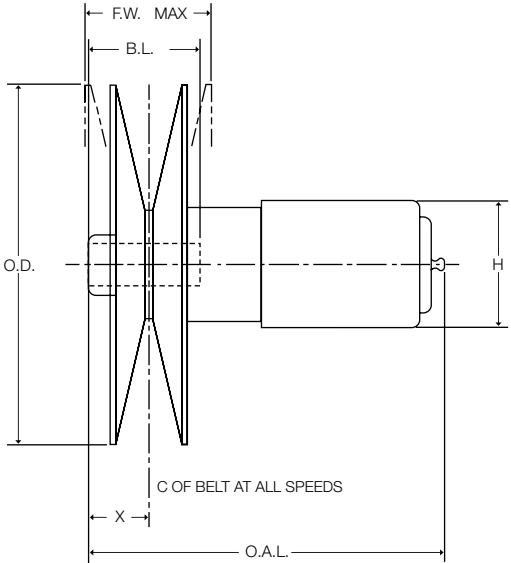

Selection Charts

RC55 (1422V BELT)

DRIVEN SPEEDS			PRODUCT NUMBER	GROOVED COMPANION SHEAVE	CENTER DISTANCE IN INCHES AT MAXIMUM AND MINIMUM SPEEDS							
3500 RPM Motor	1750 RPM Motor	1160 RPM Motor			BELT PART NUMBER							
					1422V 360	1422V 420	1422V 480	1422V 540	1422V 600	1422V 660	1422V 720	1422V 780
3500	1750	1160	531M	5.3 x 1M-SH	9.75	12.75	15.75	18.75	21.75	24.75	27.75	30.75
1166	583	387			12.37	15.39	18.41	21.42	24.43	27.44	30.45	33.45
3196	1598	1159	581M	5.8 x 1M-SH	9.36	12.36	15.36	18.36	21.36	24.36	27.36	30.36
1066	533	353			11.93	14.96	17.99	21.01	24.02	27.03	30.04	33.04
2722	1361	902	681M	6.8 x 1M-SH	8.54	11.55	14.55	17.56	20.56	23.56	26.56	29.56
908	454	301			11.02	14.09	17.13	20.16	23.18	26.19	29.21	32.22
2370	1185	785	781M	7.8 x 1M-SH	7.68	10.71	13.73	16.74	19.75	22.75	25.76	28.76
790	395	262			10.07	13.18	16.24	19.29	22.32	25.35	28.37	31.38
2100	1050	696	881M	8.8 x 1M-SH	-	9.84	12.87	15.90	18.92	21.93	24.94	27.94
700	350	232			-	12.23	15.33	18.40	21.45	24.48	27.51	30.54
1884	942	625	981M	*9.8 x 1M-SH	-	8.92	11.99	15.40	18.07	21.09	24.10	27.12
628	314	208			-	11.24	14.38	17.48	20.55	23.60	26.64	29.68
1710	855	567	1081M	*10.8 x 1M-SH	-	-	11.07	14.15	17.20	20.23	23.26	26.28
570	285	189			-	-	13.40	16.54	19.63	22.71	25.76	28.80
1564	782	518	1181M	*11.8 x 1M-SH	-	-	10.11	13.22	16.30	19.35	22.39	25.42
522	261	172			-	-	12.38	15.56	18.69	21.79	24.86	27.92
1376	668	442	1381M	*13.8 x 1M-SDS	-	-	-	11.26	14.42	17.53	20.61	23.67
446	223	148			-	-	-	13.50	16.72	19.88	23.00	26.09

*Consult factory for availability.

RC60 (1922V BELT)

DRIVEN SPEEDS			PRODUCT NUMBER	GROOVED COMPANION SHEAVE	CENTER DISTANCE IN INCHES AT MAXIMUM AND MINIMUM SPEEDS									
3500 RPM Motor	1750 RPM Motor	1160 RPM Motor			BELT PART NUMBER									
					1922V 363	1922V 403	1922V 426	1922V 454	1922V 484	1922V 544	1922V 604	1922V 666	1922V 726	1922V 756
3594	1797	1191	561N	5.6 x 1N-SK	9.23	11.23	12.38	13.78	15.28	18.28	21.28	24.38	27.38	28.88
1200	600	398			12.09	14.11	15.27	16.68	18.19	21.21	24.22	27.33	30.33	31.84
3050	1525	1011	661N	6.6 x 1N-SK	8.44	10.44	11.59	12.99	14.49	17.49	20.49	23.59	26.60	28.10
1018	509	337			11.20	13.24	14.40	15.82	17.34	20.36	23.38	26.50	29.51	31.01
2648	1324	878	761N	7.6 x 1N-SK	-	9.62	10.77	12.18	13.68	16.69	19.69	22.79	25.80	27.30
884	442	293			-	12.33	13.50	14.93	16.46	19.50	22.53	25.65	28.67	30.18
2340	1170	776	861N	8.6 x 1N-SK	-	8.75	9.92	11.33	12.84	15.86	18.87	21.98	24.98	26.49
782	391	259			-	11.38	12.57	14.02	15.56	18.62	21.66	24.79	27.82	29.33
2096	1048	695	961N	9.6 x 1N-SK	-	-	9.02	10.45	11.98	15.01	18.03	21.15	24.16	25.66
760	350	232			-	-	11.60	13.06	14.62	17.71	20.77	23.92	26.96	28.47
1898	949	629	1061N	10.6 x 1N-SK	-	-	-	9.53	11.07	14.13	17.17	20.30	23.32	24.83
634	317	210			-	-	-	12.07	13.65	16.77	19.86	23.03	26.08	27.60
1734	867	575	1161N	11.6 x 1N-SK	-	-	-	-	10.13	13.23	16.29	19.43	22.47	23.98
580	290	192			-	-	-	-	12.64	15.81	18.93	22.12	25.18	26.71
1480	740	490	1361N	13.6 x 1N-SK	-	-	-	-	-	11.30	14.44	17.64	20.70	22.23
494	247	164			-	-	-	-	-	13.77	16.98	20.23	23.34	24.88
1290	645	428	1561N	15.6 x 1N-SK	-	-	-	-	-	-	12.45	15.73	18.85	20.40
430	215	143			-	-	-	-	-	-	14.89	18.23	21.41	22.98
1194	572	379	1761N	17.6 x 1N-SK	-	-	-	-	-	-	-	13.68	16.89	18.48
382	191	127			-	-	-	-	-	-	-	-	16.10	19.37

Refer to table on page D1—52 for additional belts available.

Selection Charts

RC75 (1922V BELT)

DRIVEN SPEED		PRODUCT NUMBER	GROOVED COMPANION SHEAVE	CENTER DISTANCE IN INCHES AT MAXIMUM AND MINIMUM SPEEDS									
1750 RPM Motor	1160 RPM Motor			BELT PART NUMBER									
				1922V 363	1922V 403	1922V 426	1922V 454	1922V 484	1922V 544	1922V 604	1922V 666	1922V 726	1922V 756
2266	1502	561N	5.6 x 1N-SK	8.01	10.02	11.17	12.58	14.08	17.08	20.09	23.19	26.19	27.69
756	501			11.73	13.75	14.91	16.32	17.82	20.83	23.84	26.95	29.95	31.46
1922	1274	661N	6.6 x 1N-SK	-	9.26	10.42	11.82	13.32	16.32	19.32	22.42	25.42	26.92
642	425			-	12.88	14.05	15.46	16.98	20.00	23.01	26.12	29.13	30.64
1669	1107	761N	7.6 x 1N-SK	-	-	9.63	11.03	12.53	15.53	18.53	21.63	24.63	26.13
557	369			-	-	13.16	14.58	16.11	19.14	22.17	25.29	28.30	29.81
1475	978	861N	8.6 x 1N-SK	-	-	-	10.23	11.73	14.73	17.74	20.84	23.84	25.34
492	326			-	-	-	13.67	15.21	18.26	21.30	24.43	27.46	28.97
1322	876	961N	9.6 x 1N-SK	-	-	-	-	10.90	13.91	16.92	20.03	23.03	24.53
441	292			-	-	-	-	14.28	17.36	20.42	23.56	26.60	28.11
1197	793	1061N	10.6 x 1N-SK	-	-	-	-	-	13.06	16.08	19.20	22.21	23.71
400	265			-	-	-	-	-	-	16.44	19.52	22.68	25.72
1094	725	1161N	11.6 x 1N-SK	-	-	-	-	-	12.19	15.23	18.35	21.37	22.88
365	242			-	-	-	-	-	-	15.48	18.59	21.77	24.83
933	618	1361N	13.6 x 1N-SK	-	-	-	-	-	-	13.42	16.60	19.65	21.17
311	206			-	-	-	-	-	-	-	16.65	19.89	23.00
813	539	1561N	15.6 x 1N-SK	-	-	-	-	-	-	-	14.73	17.83	19.37
271	180			-	-	-	-	-	-	-	-	17.91	21.08
721	478	1761N	17.6 x 1N-SK	-	-	-	-	-	-	-	-	15.91	17.48
241	160			-	-	-	-	-	-	-	-	-	19.05

RC80 (2322V BELT)

DRIVEN SPEED		PRODUCT NUMBER	GROOVED COMPANION SHEAVE	CENTER DISTANCE IN INCHES AT MAXIMUM AND MINIMUM SPEEDS									
1750 RPM Motor	1160 RPM Motor			BELT PART NUMBER									
				2322V 421	2322V 441	2322V 481	2322V 521	2322V 541	2322V 601	2322V 661	2322V 721	2322V 801	2322V 1001
2055	1362	661P	6.6 x 1P-SK	9.76	10.76	12.76	14.77	15.77	18.77	21.77	24.77	28.77	38.77
684	453			13.68	14.69	16.71	18.72	19.73	22.74	25.75	28.76	32.77	42.79
1785	1183	761P	7.6 x 1P-SK	8.99	9.99	11.99	13.99	14.99	17.99	20.99	23.99	27.99	37.99
594	394			12.79	13.81	15.84	17.86	18.87	21.90	24.92	27.93	31.95	41.97
1577	1045	861P	8.6 x 1P-SK	-	9.20	11.20	13.20	14.20	17.20	20.20	23.20	27.20	37.20
525	348			-	12.90	14.94	16.98	18.00	21.04	24.06	27.09	31.11	41.15
1413	936	961P	9.6 x 1P-SK	-	-	10.38	12.38	13.39	16.39	19.40	22.40	26.40	36.41
470	312			-	-	14.02	16.08	17.10	20.15	23.20	26.23	30.26	40.32
1262	836	1081P	10.8 x 1P-SK	-	-	-	11.41	12.42	15.44	18.45	21.46	25.47	35.48
420	278			-	-	-	15.00	16.03	19.11	22.18	25.22	29.27	39.35
1154	765	1181P	11.8 x 1P-SK	-	-	-	-	11.55	14.58	17.61	20.63	24.64	34.67
384	255			-	-	-	-	15.07	18.18	21.27	24.33	28.40	38.50
986	654	1381P	13.8 x 1P-SK	-	-	-	-	-	12.79	15.86	18.91	22.95	33.01
328	218			-	-	-	-	-	-	16.24	19.38	22.49	26.60
861	571	1581P	15.8 x 1P-SK	-	-	-	-	-	-	13.99	17.10	21.19	31.31
287	190			-	-	-	-	-	-	-	17.38	20.56	24.73
764	506	1781P	17.8 x 1P-SK	-	-	-	-	-	-	-	15.17	19.34	29.57
254	169			-	-	-	-	-	-	-	-	18.52	22.78

Refer to table on page D1-53 for additional belts available.

Selection Charts

RC105 (2926V BELT)

DRIVEN SPEED		PRODUCT NUMBER	GROOVED COMPANION SHEAVE	CENTER DISTANCE IN INCHES AT MAXIMUM AND MINIMUM SPEEDS								
1750 RPM Motor	1160 RPM Motor			BELT PART NUMBER								
				2926V 574	2926V 606	2926V 646	2926V 686	2926V 726	2926V 834	2926V 906	2926V 1006	
2390 594	1584 394	761T	7.6 x 1T-SK	14.50	16.11	18.12	20.12	22.13	27.54	31.14	36.15	
				20.54	22.15	24.16	26.17	28.18	33.60	37.21	42.22	
2112 525	1400 348	861T	8.6 x 1T-SK	13.76	15.36	17.37	19.37	21.37	26.78	30.38	35.38	
				19.67	21.29	23.31	25.32	27.34	32.77	36.38	41.40	
1892 470	1254 312	961T	9.6 x 1T-SK	13.00	14.60	16.60	18.60	20.60	26.00	29.60	34.60	
				18.78	20.41	22.44	24.46	26.48	31.92	35.54	40.57	
1714 426	1136 282	1061T	10.6 x 1T-SK	12.22	13.82	15.82	17.82	19.82	25.22	28.82	33.82	
				17.87	19.51	21.55	23.58	25.61	31.07	34.70	39.73	
1566 389	1038 258	1161T	11.6 x 1T-SK	-	13.02	15.02	17.02	19.02	24.43	28.03	38.03	
				-	18.58	20.64	22.68	24.72	30.20	33.84	38.88	
1336 332	885 220	1361T	13.6 x 1T-SK	-	-	13.36	15.37	17.38	22.80	26.41	31.42	
				-	-	18.75	20.82	22.89	28.42	32.08	37.15	
1164 289	772 192	1561T	15.6 x 1T-SK	-	-	-	-	15.66	21.12	24.74	29.77	
				-	-	-	-	20.97	26.58	30.28	35.38	
1032 257	684 170	1761T	17.6 x 1T-SK	-	-	-	-	-	19.36	23.02	28.07	
				-	-	-	-	-	24.66	28.40	33.56	
927 230	614 153	1961T	19.6 x 1T-SK	-	-	-	-	-	17.51	21.22	26.32	
				-	-	-	-	-	22.65	26.46	31.68	

RC100 (2926V BELT)

DRIVEN SPEED		PRODUCT NUMBER	GROOVED COMPANION SHEAVE	CENTER DISTANCE IN INCHES AT MAXIMUM AND MINIMUM SPEEDS								
1750 RPM Motor	1160 RPM Motor			BELT PART NUMBER								
				2926V 574	2926V 606	2926V 646	2926V 686	2926V 726	2926V 834	2926V 906	2926V 1006	
2245 748	1488 496	761T	7.6 x 1T-SK	15.03	16.63	18.43	20.64	22.64	28.05	31.65	36.65	
				20.05	21.66	23.67	25.68	27.68	33.10	36.71	41.72	
1984 661	1315 438	861T	8.6 x 1T-SK	14.27	15.87	17.88	19.88	21.88	27.28	30.88	35.88	
				19.19	20.81	22.82	24.84	26.85	32.27	35.88	40.90	
1777 592	1178 393	961T	9.6 x 1T-SK	13.50	15.10	17.10	19.10	21.10	26.50	30.10	35.10	
				18.31	19.93	21.96	23.98	26.00	31.43	35.05	40.07	
1610 537	1067 356	1061T	10.6 x 1T-SK	12.71	14.31	16.31	18.31	20.31	25.71	29.31	34.31	
				17.41	19.04	21.08	23.11	25.13	30.58	34.21	39.23	
1471 490	975 325	1161T	11.6 x 1T-SK	-	13.50	15.50	17.50	19.51	24.91	28.51	33.52	
				-	18.13	20.17	22.22	24.25	29.72	33.35	38.39	
1255 418	832 277	1361T	13.6 x 1T-SK	-	-	13.81	15.83	17.85	23.27	26.88	31.90	
				-	-	18.30	20.37	22.43	27.95	31.61	36.67	
1294 365	725 242	1561T	15.6 x 1T-SK	-	-	-	14.06	16.10	21.57	25.20	30.23	
				-	-	-	18.93	20.53	26.12	29.81	34.91	
969 323	643 214	1761T	17.6 x 1T-SK	-	-	-	-	-	19.80	23.46	28.53	
				-	-	-	-	-	24.21	27.85	33.10	
871 290	577 192	1961T	19.6 x 1T-SK	-	-	-	-	-	17.94	21.65	26.76	
				-	-	-	-	-	22.22	26.02	31.23	

Refer to table on page D1—53 for additional belts available.



Selection Charts

RC1315 (4430V BELT)

DRIVEN SPEED		PRODUCT NUMBER	GROOVED COMPANION SHEAVE	CENTER DISTANCE IN INCHES AT MAXIMUM AND MINIMUM SPEEDS							
1750 RPM Motor	1160 RPM Motor			BELT PART NUMBER							
				4430V 730	4430V 790	4430V 850	4430V 910	4430V 970	4430V 1090	4430V 1320	4430V 1610
2028 676	1345 448	1101W	11.0 x 1W-SF	17.82	20.82	23.83	26.83	29.83	35.83	47.34	61.84
				24.27	27.30	30.32	33.34	36.35	42.38	53.91	68.43
1859 620	1233 411	1201W	12.0 x 1W-SF	17.05	20.06	23.06	26.06	29.06	35.06	46.56	61.06
				23.39	26.43	29.46	32.49	35.51	41.54	53.08	67.61
1716 572	1138 379	1301W	13.0 x 1W-SF	16.27	19.27	22.27	25.27	28.27	34.27	45.77	60.27
				22.50	25.55	28.59	31.62	34.65	40.70	52.25	66.79
1594 531	1056 352	1401W	14.0 x 1W-SF	15.47	18.48	21.48	24.48	27.48	33.48	44.98	59.48
				21.58	24.65	27.70	30.75	33.79	39.84	51.41	65.97
1488 496	986 329	1501W	15.0 x 1W-SF	-	17.66	20.67	23.67	26.68	32.68	44.19	58.69
				-	23.73	26.80	29.86	32.91	38.98	50.57	65.14
1395 465	924 308	1601W	16.0 x 1W-SF	-	16.83	19.84	22.85	25.86	31.87	43.38	57.89
				-	22.80	25.89	28.96	32.02	38.11	49.72	64.30
1240 413	822 274	1801W	18.0 x 1W-SF	-	-	18.14	21.17	24.19	30.22	41.76	56.28
				-	-	23.99	27.10	30.19	36.33	47.99	62.61
1116 372	740 247	2001W	20.0 x 1W-SF	-	-	-	19.41	22.46	28.53	40.10	54.64
				-	-	-	25.17	28.30	34.50	46.23	60.90
1014 338	672 224	2201W	22.0 x 1W-SF	-	-	-	-	20.65	26.78	38.40	52.98
				-	-	-	-	26.34	32.61	44.43	59.16
930 310	616 205	2401W	24.0 x 1W-SF	-	-	-	-	-	24.96	36.67	51.30
				-	-	-	-	-	30.66	42.60	57.40
797 266	528 176	2801W	28.0 x 1W-E	-	-	-	-	-	-	33.06	47.84
				-	-	-	-	-	-	38.78	53.77

RC1330 (4430V BELT)

DRIVEN SPEED		PRODUCT NUMBER	GROOVED COMPANION SHEAVE	CENTER DISTANCE IN INCHES AT MAXIMUM AND MINIMUM SPEEDS							
1750 RPM Motor	1160 RPM Motor			BELT PART NUMBER							
				4430V 730	4430V 790	4430V 850	4430V 910	4430V 970	4430V 1090	4430V 1320	4430V 1610
2028 737	1345 488	1101W	11.0 x 1W-SF	17.82	20.82	23.83	26.83	29.83	35.83	47.34	61.84
				23.99	27.02	30.04	33.06	36.07	42.09	53.62	68.14
1859 675	1233 448	1201W	12.0 x 1W-SF	17.05	20.06	23.06	26.06	29.06	35.06	46.56	61.06
				23.12	26.16	29.19	32.21	35.23	41.26	52.80	67.33
1716 623	1138 413	1301W	13.0 x 1W-SF	16.27	19.27	22.27	25.27	28.27	34.27	45.77	60.27
				22.23	25.28	28.32	31.35	34.38	40.42	51.97	66.51
1594 579	1056 384	1401W	14.0 x 1W-SF	15.47	18.48	21.48	24.48	27.48	33.48	44.98	59.48
				21.32	24.39	27.44	30.48	33.51	39.57	51.13	65.68
1488 540	986 358	1501W	15.0 x 1W-SF	-	17.66	20.67	23.67	26.68	32.68	44.19	58.69
				-	23.47	26.54	29.59	32.64	38.71	50.29	64.86
1395 506	924 336	1601W	16.0 x 1W-SF	-	16.83	19.84	22.85	25.86	31.87	43.38	57.89
				-	22.54	25.63	28.69	31.75	37.84	49.44	64.02
1240 450	822 298	1801W	18.0 x 1W-SF	-	-	18.14	21.17	24.19	30.22	41.76	56.28
				-	-	23.74	26.85	29.93	36.06	47.72	62.34
1116 405	740 269	2001W	20.0 x 1W-SF	-	-	-	19.41	22.46	28.53	40.10	54.64
				-	-	-	24.92	28.05	34.24	45.96	60.63
1014 368	672 244	2201W	22.0 x 1W-SF	-	-	-	-	20.65	26.78	38.40	52.98
				-	-	-	-	26.09	32.36	44.17	58.89
930 338	616 224	2401W	24.0 x 1W-SF	-	-	-	-	-	24.96	36.67	51.30
				-	-	-	-	-	30.41	42.34	57.13
797 289	528 192	2801W	28.0 x 1W-E	-	-	-	-	-	-	33.06	47.84
				-	-	-	-	-	-	38.53	53.51

Refer to table on page D1—53 for additional belts available.

Roto-Cone® Type W

Dimensions

Fixed Center Drive

1/4 - 25 HP @ 1750 rpm

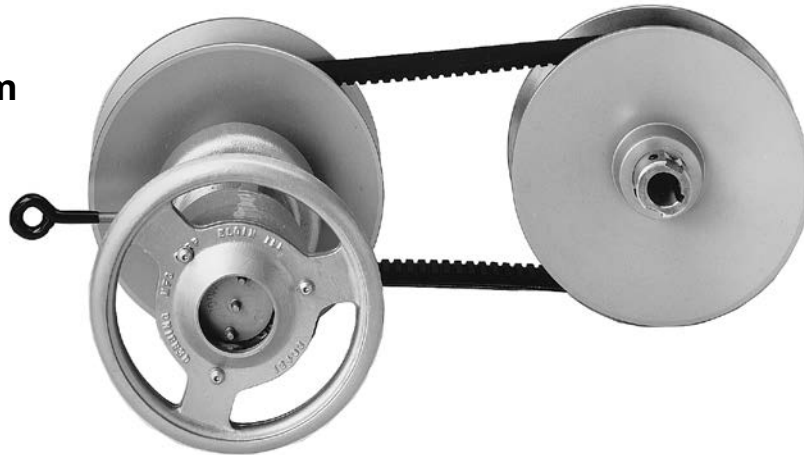

Standard Bores

Model	Standard Bores
RC55W	1/2, 5/8
RC60W	5/8, 3/4
RC75W	5/8, 3/4, 7/8
RC80W	3/4, 7/8, 1, 1-1/8
RC105W	3/4, 7/8, 1-1/8
RC100W	1-1/8, 1-1/4
RC1315W	1-3/8, 1-5/8
RC1330W	1-1/4, 1-5/8, 1-7/8

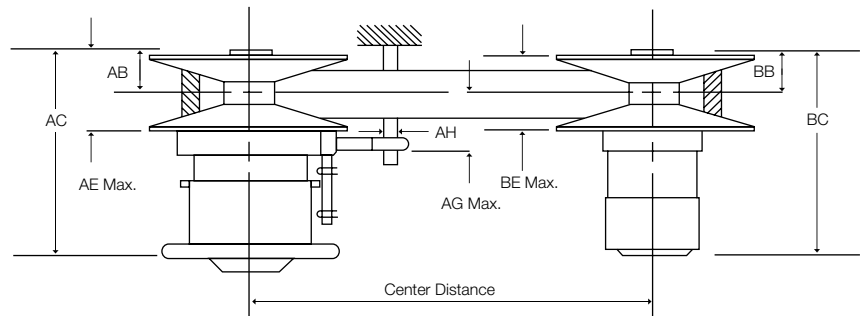
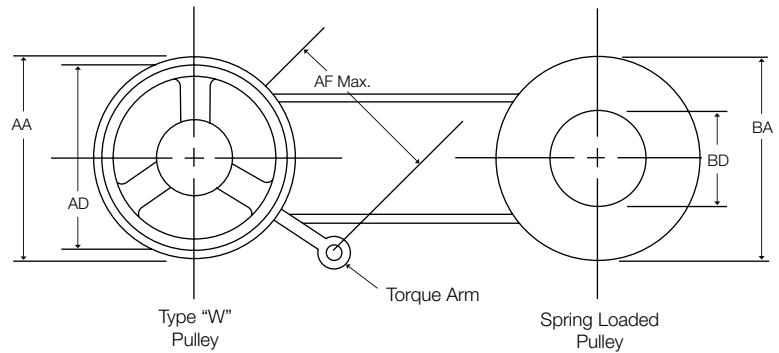

Roto-Cone Type W Dimensions

Driver Model	Driven Model	AA	AB	AC	AD	AE Max.	AF Max.	AG Max.	AH	BA	BB	BC	BD	BE Max.
RC55W	RC55	5.50	1.00	6.31	5.50	1.81	4.00	1.81	.50	5.50	1.00	4.75	2.06	1.18
RC60W	RC60	6.00	.94	6.75	5.50	2.25	4.00	2.38	.50	6.00	.94	5.75	2.25	2.25
RC75W	RC75	7.50	1.25	8.31	7.50	2.63	6.25	2.13	.63	7.50	1.25	7.13	2.63	2.63
RC80W	RC80	8.00	1.44	9.19	7.50	2.75	6.25	2.88	.63	8.00	1.44	8.00	2.88	2.75
RC105W	RC105	10.63	1.81	9.19	7.50	3.00	6.25	2.19	.63	10.63	1.81	8.00	2.88	3.25
RC100W	RC100	10.00	2.06	11.88	9.00	3.88	6.25	3.69	.63	10.00	2.06	10.19	3.63	3.88
RC1315W	RC1315	13.00	2.25	15.44	12.00	5.38	9.50	5.06	.63	13.00	2.25	12.56	4.50	5.38
RC1330W	RC1330	13.00	2.50	14.25	12.00	5.38	9.50	3.75	.88	13.00	2.50	12.00	6.25	5.63

Dimensions

1/4 - 25 HP @ 1750 rpm

LINE NUMBER	HP RATING @1750	PULLEY MODELS		DRIVEN SPEEDS 1750 RPM DRIVER		CENTER DISTANCE (IN.)								
						1422V BELT								
						360	420	480	540	600	660	720	780	
1	0.25	RC55W	RC55	5000	600	12.45	15.45	18.45	21.45	24.45	27.45	30.45	33.45	
						1922V BELT								
						363	403	426	454	484	544	604	666	726
2	0.5	RC60W	RC60	5000	600	12.05	14.05	15.2	16.6	18.1	21.1	24.1	27.2	30.2
3	1	RC60W	RC75	2700	490	10.79	12.79	13.94	15.34	16.84	19.84	22.84	25.94	28.94
4	1.5	RC75W	RC75	4800	600	10.47	12.47	13.62	15.02	16.52	19.52	22.52	25.62	28.62
						2322V BELT								
						441	481	521	541	601	661	721	801	1001
5	2	RC80W	RC80	4400	600	13.7	15.7	17.7	18.7	21.7	24.7	27.7	31.7	41.7
						2926V BELT								
						574	606	646	686	726	834	906	1006	
6	3	RC105W	RC105	3600	450	18.2	19.8	21.8	23.8	25.8	31.2	34.8	39.8	
7	5	RC100W	RC100	3820	600	18.1	19.7	21.7	23.7	25.7	31.1	34.7	39.7	
						4430V BELT								
						730	790	850	910	970	1030	1090	1150	1320
8	15	RC1315W	RC1315	3000	600	22.7	25.7	28.7	31.7	34.7	37.7	40.7	43.7	52.2

The following charts are based around a 1750 rpm motor. All other motor speeds will be proportional.

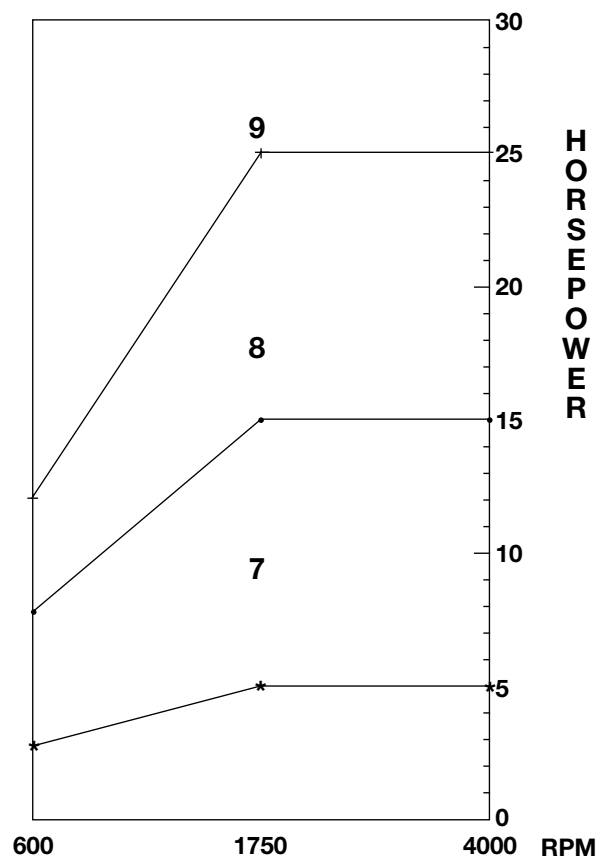
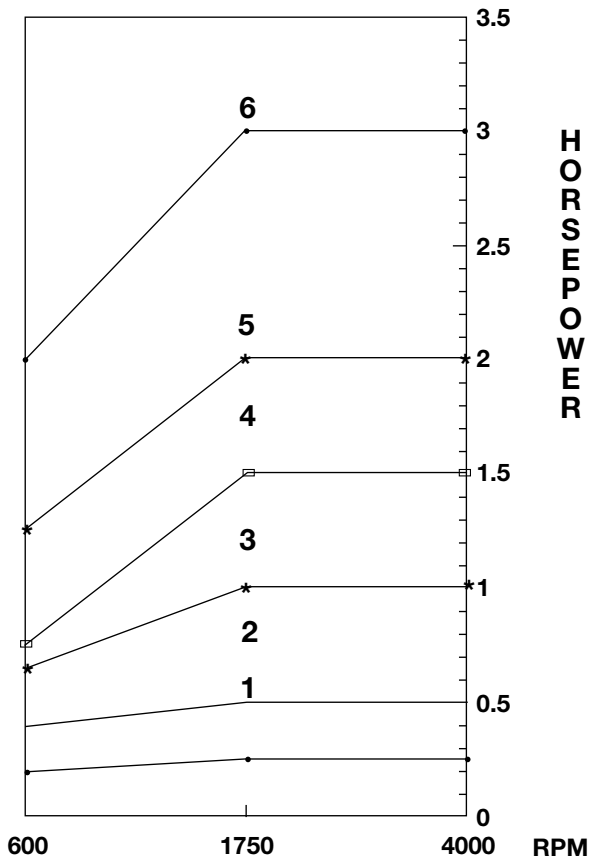

Graphs show horsepower rating for line number indicated.

Selection Charts

MODEL NO.	HP @ RPM		SPEED RATIO	BELT SECTION	PITCH DIA.		DRIVE CHART PAGE NO.
	1750	1160			MAX.	MIN.	
VC30	1/3	1/4	1.7:1	A	3.4	2.0	D1-33
VC40	1/2	1/3	2.0:1	A	4.0	2.0	D1-33
VC51	1	1/2	1.7:1	B	5.1	3.0	D1-34
VC57	2	1	2.2:1	B	5.8	2.7	D1-34

Horsepower ratings are based on constant torque and are shown for maximum pitch diameters.
Horsepower ratings at other pitch diameters reduce in proportion to the speed.



FEATURES

- Cast Iron Construction
- No Lubrication
- Thru Shaft Mounting
- Economical, Compact Design
- 1/2 HP thru 2 HP @ 1750 rpm

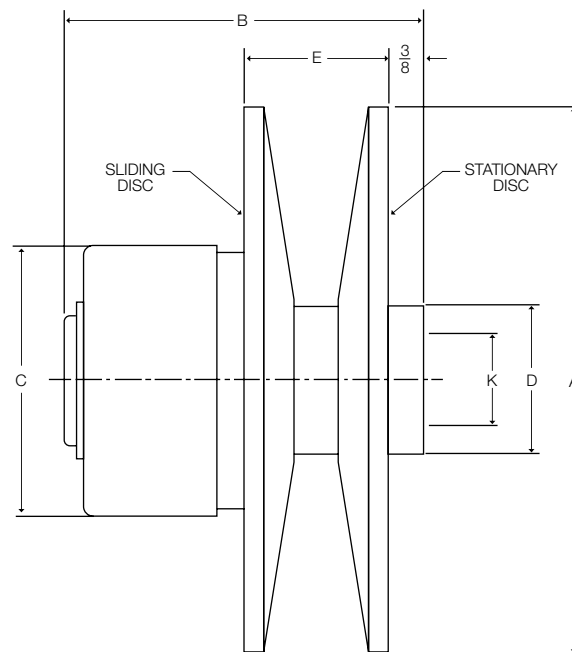

Dimensions

MODEL NO.	DIMENSIONS IN INCHES					MAX.	WEIGHT BORE	LBS.
	A	B	C	D	E*	STOCK BORE		
VC30	3.38	2.77	2.13	1.38	1.09	1/2, 5/8, 3/4	3/4	1.8
VC40	4.00	2.88	2.13	1.38	1.25	1/2, 5/8, 3/4	3/4	2.5
VC51	5.25	3.69	2.95	1.63	1.46	5/8, 3/4, 7/8, 1	1-1/8	4.5
VC57	6.00	3.94	2.95	1.63	1.59	5/8, 3/4, 7/8, 1	1-1/8	6.8

* Maximum Dimension

ORDERING EXAMPLE: VC40 X 5/8

Bores and Keyseats

BORE	KEYSEAT
1/2	NONE
5/8 - 3/4 - 7/8	3/16 x 3/32
1"	1/4 x 1/8

Selection Charts

VC30 (A and 4L BELTS)

DRIVEN SPEEDS				FHP COMPANION SHEAVE PRODUCT NUMBER	MINIMUM CENTER DISTANCE (ADD 1" FOR MAXIMUM)								
1750 RPM		1160 RPM			BELT NUMBER								
MAX. SPEED	MIN. SPEED	MAX. SPEED	MIN. SPEED		AP25	AP30	AP35	AP40	AP45	AP55	AP65	AP75	AP80
1777	1034	1178	685	AK32	7.93	10.43	12.93	15.43	17.93	22.93	27.93	32.93	35.43
1543	898	1023	595	AK39	7.53	10.03	12.53	15.03	17.53	22.53	27.53	32.53	35.03
1466	853	972	566	AK41	7.37	9.87	12.37	14.87	17.37	22.37	27.37	32.37	34.87
1363	794	904	526	AK44	7.12	9.63	12.13	14.63	17.13	22.14	27.14	32.14	34.64
1106	644	733	427	AK54	6.27	8.80	11.31	13.82	16.32	21.33	26.34	31.34	33.84
1011	588	670	390	AK59	5.83	8.37	10.89	13.40	15.91	20.92	25.93	30.94	33.44
931	542	617	359	AK64	-	7.92	10.46	12.98	15.49	20.51	25.52	30.53	33.03
803	467	532	310	AK74	-	6.99	9.57	12.11	14.64	19.68	24.70	29.71	32.22
706	411	468	273	AK84	-	-	8.63	11.21	13.76	18.82	23.86	28.88	31.39
630	367	418	243	AK94	-	-	7.63	10.26	12.85	17.95	23.01	28.04	30.56
543	316	360	209	AK109	-	-	-	8.74	11.41	16.59	21.69	26.76	29.28
477	277	316	184	AK124	-	-	-	-	9.85	15.17	20.33	25.43	27.97
383	223	254	148	AK154	-	-	-	-	-	12.06	17.45	22.67	25.25

VC40 (A and 4L BELTS)

DRIVEN SPEEDS				FHP COMPANION SHEAVE PRODUCT NUMBER	MINIMUM CENTER DISTANCE (ADD 1.12" FOR MAXIMUM)								
1750 RPM		1160 RPM			BELT NUMBER								
MAX. SPEED	MIN. SPEED	MAX. SPEED	MIN. SPEED		AP25	AP30	AP35	AP40	AP45	AP55	AP65	AP75	AP80
2121	1034	1406	685	AK32	7.41	9.91	12.41	14.91	17.41	22.41	27.41	32.41	34.91
1842	898	1221	595	AK39	7.02	9.51	12.02	14.52	17.02	22.02	27.02	32.02	34.52
1750	853	1160	566	AK41	6.87	9.37	11.87	14.37	16.87	21.87	26.87	31.87	34.37
1628	794	1079	526	AK44	6.63	9.13	11.63	14.13	16.63	21.63	26.63	31.63	34.13
1321	644	875	427	AK54	5.81	8.32	10.82	13.33	15.83	20.83	25.84	30.84	33.34
1207	588	800	390	AK59	-	7.90	10.41	12.92	15.42	20.43	25.43	30.44	32.94
1111	542	737	359	AK64	-	7.46	9.99	12.50	15.01	20.02	25.03	30.04	32.54
959	467	636	310	AK74	-	6.55	9.11	11.65	14.17	19.20	24.21	29.22	31.73
843	411	559	273	AK84	-	-	8.19	10.76	13.30	18.35	23.38	28.40	30.91
753	367	499	243	AK94	-	-	-	9.83	12.40	17.49	22.53	27.56	30.08
648	316	430	209	AK109	-	-	-	8.33	10.98	16.14	21.23	26.29	28.81
569	277	377	184	AK124	-	-	-	-	9.44	14.73	19.89	24.98	27.51
458	223	303	148	AK154	-	-	-	-	-	11.65	17.02	22.23	24.81

Refer to table on page D1—35 for additional companions available.
Refer to table on page D1—40 for additional belts available.

Selection Charts

VC51 (B and 5L BELTS)

DRIVEN SPEEDS				FHP COMPANION SHEAVE PRODUCT NUMBER	MINIMUM CENTER DISTANCE (ADD 1.75" FOR MAXIMUM)									
1750 RPM		1160 RPM			BELT NUMBER									
MAX. SPEED	MIN. SPEED	MAX. SPEED	MIN. SPEED		BP25	BP30	BP35	BP40	BP45	BP55	BP65	BP75	BP80	
2047	1184	1357	785	BK46	6.46	8.46	10.96	13.46	15.96	20.97	25.97	30.97	33.47	
1697	981	1125	651	BK55	-	7.76	10.26	12.76	15.26	20.26	25.26	30.26	32.76	
1635	946	1084	627	BK57	-	7.60	10.10	12.60	15.10	20.10	25.10	30.10	32.60	
1497	866	993	574	BK62	-	7.20	9.70	12.20	14.71	19.71	24.71	29.71	32.21	
1382	799	916	530	BK67	-	6.78	9.29	11.80	14.30	19.31	24.31	29.31	31.81	
1320	764	875	506	BK72	-	-	9.04	11.55	14.06	19.06	24.07	29.07	31.57	
1196	692	793	459	BK77	-	-	8.45	10.97	13.48	18.49	23.50	28.51	31.01	
1019	589	675	391	BK90	-	-	-	9.83	12.37	17.41	22.43	27.45	29.95	
914	529	606	351	BK100	-	-	-	8.91	11.48	16.55	21.59	26.62	29.13	
793	458	525	304	BK115	-	-	-	-	10.06	15.22	20.30	25.35	27.86	
759	439	503	291	BK120	-	-	-	-	9.56	14.76	19.86	24.92	27.44	
699	405	464	268	BK130	-	-	-	-	-	13.81	18.96	24.04	26.57	
566	328	375	217	BK160	-	-	-	-	-	-	16.10	21.31	23.88	

VC57 (B and 5L BELTS)

DRIVEN SPEEDS				FHP COMPANION SHEAVE PRODUCT NUMBER	MINIMUM CENTER DISTANCE (ADD 2.6" FOR MAXIMUM)									
1750 RPM		1160 RPM			BELT NUMBER									
MAX. SPEED	MIN. SPEED	MAX. SPEED	MIN. SPEED		BP25	BP30	BP35	BP40	BP45	BP55	BP65	BP75	BP80	
2308	1064	1530	705	BK46	5.91	7.93	10.43	12.94	15.44	20.45	25.45	30.45	32.95	
1913	882	1268	584	BK55	-	7.25	9.75	12.25	14.75	19.75	24.75	29.75	32.25	
1843	849	1222	563	BK57	-	7.09	9.59	12.09	14.59	19.59	24.59	29.59	32.09	
1688	778	1119	516	BK62	-	-	9.20	11.70	14.20	19.20	24.20	29.20	31.70	
1558	718	1033	476	BK67	-	-	8.80	11.30	13.80	18.81	23.81	28.81	31.31	
1489	686	987	455	BK72	-	-	8.56	11.06	13.56	18.57	23.57	28.57	31.07	
1349	622	894	412	BK77	-	-	7.97	10.49	12.99	18.00	23.01	28.01	30.51	
1149	529	761	351	BK90	-	-	-	9.37	11.90	16.93	21.95	26.96	29.46	
1031	475	683	315	BK100	-	-	-	-	11.02	16.08	21.11	26.13	28.64	
894	412	592	273	BK115	-	-	-	-	9.63	14.76	19.83	24.87	27.39	
856	394	567	261	BK120	-	-	-	-	-	14.31	19.40	24.45	26.96	
789	363	523	241	BK130	-	-	-	-	-	13.38	18.51	23.58	26.11	
638	294	423	195	BK160	-	-	-	-	-	-	15.68	20.87	23.44	

Refer to table on page D1-35 for additional companions available.
 Refer to table on page D1-40 for additional belts available.

Light Duty Sheaves

AK QT SHEAVES

DATUM DIA.	O.D. ◆	SINGLE-GROOVE						Wt. (lbs.)
		PRODUCT NO.	TYPE	DIMENSIONS				
A (4L) Belts	E			F	L	M		
2.8	3.0	AK30	E1	3/8	3/4	1-1/4	7/8	1.7
3.0	3.2	AK32	E1	3/8	3/4	1-1/4	7/8	1.8
3.2	3.4	AK34	C2	1/16	3/4	1-1/4	9/16	1.6
3.5	3.7	AK39	C2	1/16	3/4	1-1/4	9/16	2.0
3.7	3.9	AK41	C2	1/16	3/4	1-1/4	9/16	2.2
4.0	4.2	AK44	C2	1/16	3/4	1-1/4	9/16	2.5
4.2	4.4	AK46	C2	1/16	3/4	1-1/4	9/16	2.5
4.5	4.7	AK49	C2	1/16	3/4	1-1/4	9/16	2.6
4.7	4.9	AK51	C2	1/16	3/4	1-1/4	9/16	2.9
5.0	5.2	AK54	C2	1/16	3/4	1-1/4	9/16	2.6
5.2	5.4	AK56	C2	1/16	3/4	1-1/4	9/16	2.9
5.5	5.7	AK59	C2	1/16	3/4	1-1/4	9/16	3.0
5.7	5.9	AK61	D3	1/16	3/4	1-1/4	9/16	3.1
6.0	6.2	AK64	D3	1/16	3/4	1-1/4	9/16	3.3
6.2	6.4	AK66	D3	1/16	3/4	1-1/4	9/16	3.4
6.5	6.7	AK69	D3	1/16	3/4	1-1/4	9/16	3.8
6.7	6.9	AK71	D3	1/16	3/4	1-1/4	9/16	3.6
7.0	7.2	AK74	D3	1/16	3/4	1-1/4	9/16	3.9
7.5	7.7	AK79	D3	1/16	3/4	1-1/4	9/16	4.1
8.0	8.2	AK84	D3	1/16	3/4	1-1/4	9/16	4.2
8.5	8.7	AK89	D3	1/16	3/4	1-1/4	9/16	4.6
9.0	9.2	AK94	D3	1/16	3/4	1-1/4	9/16	5.0
9.5	9.7	AK99	D3	1/16	3/4	1-1/4	9/16	5.0
10.0	10.2	AK104	D3	1/16	3/4	1-1/4	9/16	5.1
10.5	10.7	AK109	D3	1/16	3/4	1-1/4	9/16	5.6
11.0	11.2	AK114	D3	1/16	3/4	1-1/4	9/16	6.1
12.0	12.2	AK124	D3	1/16	3/4	1-1/4	9/16	6.6
13.0	13.2	AK134	D3	1/16	3/4	1-1/4	9/16	8.0
14.0	14.2	AK144	D3	1/16	3/4	1-1/4	9/16	8.4
15.0	15.2	AK154	D3	1/16	3/4	1-1/4	9/16	9.4
18.0	18.2	AK184	D3	1/16	3/4	1-1/4	9/16	11.9

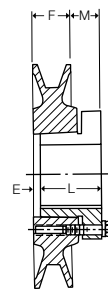

Type C2

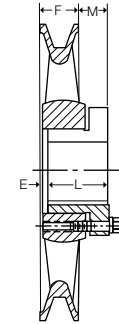

Type D3

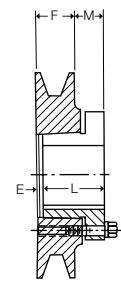

Type E1

BK QT SHEAVES

DATUM DIA.	O.D. ◆	SINGLE-GROOVE						Wt. (lbs.)	
		PRODUCT NO.	TYPE	DIMENSIONS					
A (4L) Belts	B (5L) Belts			E	F	L	M		
2.4	2.8	3.1	BK30	E1	1/2	7/8	1-1/4	7/8	1.8
2.6	3.0	3.3	BK32	E1	1/2	7/8	1-1/4	7/8	2.0
2.8	3.2	3.5	BK34	E1	1/2	7/8	1-1/4	7/8	2.2
3.0	3.4	3.7	BK36	C2	1/16	7/8	1-1/4	7/16	1.6
3.2	3.6	3.9	BK40	C2	1/16	7/8	1-1/4	7/16	2.0
3.5	3.9	4.2	BK45	C2	1/16	7/8	1-1/4	7/16	2.4
3.7	4.1	4.4	BK47	C2	1/16	7/8	1-1/4	7/16	2.8
4.0	4.4	4.7	BK50	C2	1/16	7/8	1-1/4	7/16	2.6
4.2	4.6	4.9	BK52	C2	1/16	7/8	1-1/4	7/16	2.7
4.5	4.9	5.2	BK55	C2	1/16	7/8	1-1/4	7/16	3.2
4.7	5.1	5.4	BK57	D3	1/16	7/8	1-1/4	7/16	3.3
5.0	5.4	5.7	BK60	D3	1/16	7/8	1-1/4	7/16	3.1
5.2	5.6	5.9	BK62	D3	1/16	7/8	1-1/4	7/16	3.2
5.5	5.9	6.2	BK65	D3	1/16	7/8	1-1/4	7/16	3.4
5.7	6.1	6.4	BK67	D3	1/16	7/8	1-1/4	7/16	3.5
6.0	6.4	6.7	BK70	D3	1/8	7/8	1-1/4	1/2	3.4
6.2	6.6	6.9	BK72	D3	1/8	7/8	1-1/4	1/2	3.7
6.5	6.9	7.2	BK75	D3	1/8	7/8	1-1/4	1/2	3.9
6.7	7.1	7.4	BK77	D3	1/8	7/8	1-1/4	1/2	4.4
7.0	7.4	7.7	BK80	D3	1/8	7/8	1-1/4	1/2	4.0
7.5	7.9	8.2	BK85	D3	1/8	7/8	1-1/4	1/2	4.4
8.0	8.4	8.7	BK90	D3	1/8	7/8	1-1/4	1/2	4.9
8.5	8.9	9.2	BK95	D3	1/8	7/8	1-1/4	1/2	5.6
9.0	9.4	9.7	BK100	D3	1/8	7/8	1-1/4	1/2	5.8
9.5	9.9	10.2	BK105	D3	1/8	7/8	1-1/4	1/2	6.1
10.0	10.4	10.7	BK110	D3	1/8	7/8	1-1/4	1/2	6.6
10.5	10.9	11.2	BK115	D3	1/8	7/8	1-1/4	1/2	7.0
11.0	11.4	11.7	BK120	D3	1/8	7/8	1-1/4	1/2	7.5
12.0	12.4	12.7	BK130	D3	1/8	7/8	1-1/4	1/2	7.5
13.0	13.4	13.7	BK140	D3	1/8	7/8	1-1/4	1/2	9.1
14.0	14.4	14.7	BK150	D3	1/8	7/8	1-1/4	1/2	9.2
15.0	15.4	15.7	BK160	D3	1/8	7/8	1-1/4	1/2	10.4
18.0	18.4	18.7	BK190	D3	1/8	7/8	1-1/4	1/2	13.4

Weights for all Sure-Grip bushed items are approximate and include the bushing.

◆ P.D. same as O.D.

QT BUSHINGS

Product No.	Bore	Key Seat	Wt. (lb.)	Product No.	Bore (mm)	Key ■	Wt. (lb.)
QTMPIB	7/16	No KS	.6	QT14MM	14	5 x 5	.6
QT12	1/2	1/8 x 1/16	.6	QT15MM	15	5 x 5	.6
QT9/16	9/16	1/8 x 1/16	.6	QT16MM	16	5 x 5	.6
QT58	5/8	3/16 x 3/32	.6	QT18MM	18	6 x 6	.6
QT11/16	11/16	3/16 x 3/32	.6	QT19MM	19	6 x 6	.6
QT34	3/4	3/16 x 3/32	.6	QT20MM	20	6 x 6	.6
QT13/16	13/16	3/16 x 3/32	.6	QT22MM	22	6 x 6	.6
QT78	7/8	3/16 x 3/32	.6	QT24MM	24	8 x 7	.6
QT15/16	15/16	1/4 x 1/8	.6	QT25MM	25	8 x 7	.6
QT1	1	1/4 x 1/8	.6	QT28MM	28	8 x 7	.6
QT1116	1-1/16	1/4 x 1/8	.6	QT30MM	30	8 x 7	.6
QT118	1-1/8	1/4 x 1/8	.6	QT32MM	32	10 x 6	.6
QT1316	1-3/16	1/4 x 1/8	.6	QT35MM	35	10 x 6	.6
QT114	1-1/4	1/4 x 1/8	.6	QT38MM	38	10 x 6	.6
QT1516	1-5/16	5/16 x 1/16	.6				
QT138	1-3/8	5/16 x 1/16	.6				
QT1716	1-7/16	3/8 x 1/16	.6				
QT112	1-1/2	3/8 x 1/16	.6				

* Approximate weight in lbs.

■ The metric system does not refer to keyseat or keyway dimensions as does the English system; instead, dimensions are given for the key itself, which is rectangular in shape and not square as in the English system. This meets ISO standards.

Weights for all Sure-Grip bushed items are approximate and include the bushing.

◆ P.D. for A belts = Datum Dia. + .38

P.D. for B belts = Datum Dia. + .36

Fixed Center Drive Dual-Groove Var-A-Cone®

FIXED CENTER DRIVE DUAL-GROOVE VAR-A-CONE®

Fractional thru 1 HP

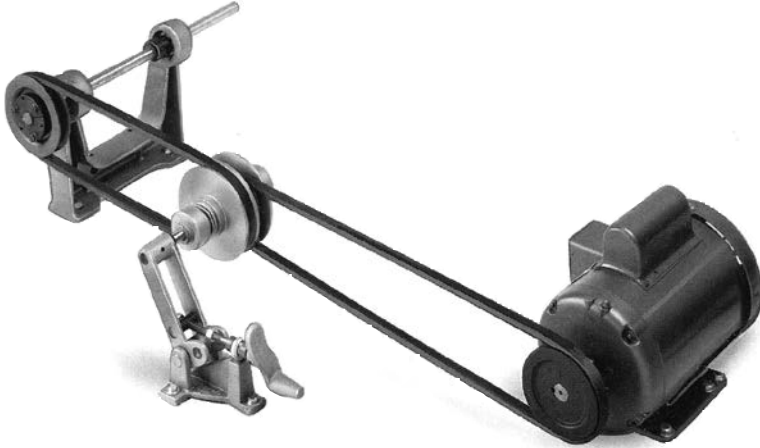

Selection

1. Determine desired maximum and minimum driven speed.
2. Select suitable DUAL-GROOVE pulley model dependent on required horsepower and speed ratio.
3. Divide maximum desired speed by the square root of the DUAL-GROOVE pulley speed ratio to obtain mean driven speed.

$$\text{Mean driven speed} = \frac{\text{Max. driven speed}}{\sqrt{\text{Speed ratio}}}$$

4. Determine required driver and driven pulley diameters to obtain the mean driven speed.

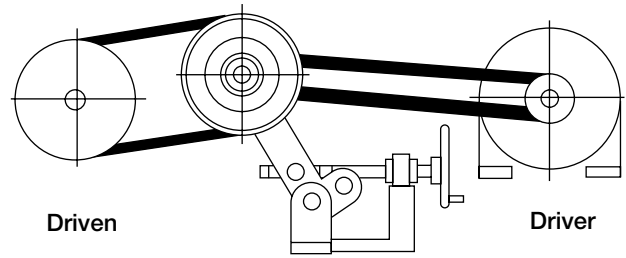
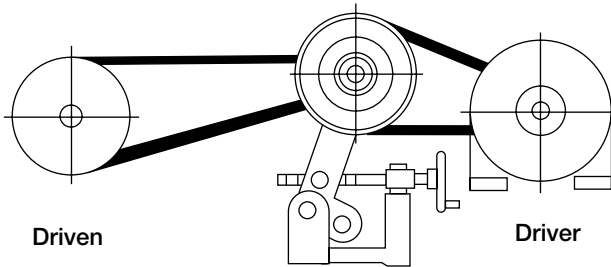

Fixed Center Drive Dual-Groove Var-A-Cone®

Dimensions

Pulley Specifications

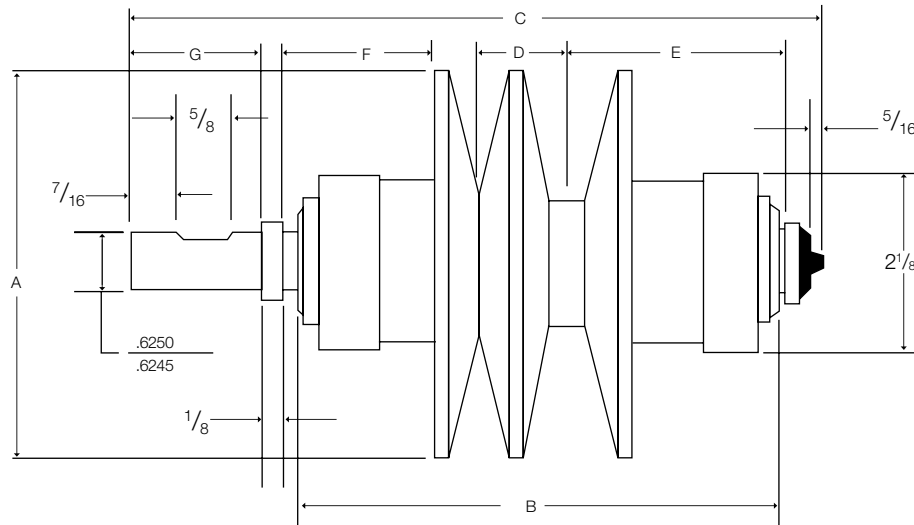

Product No.	Speed Ratio	Belt Size	Driver* Pulley P.D.	Horsepower			Dimensions in Inches							Pitch Dia.	
				Low Speed	Mean Speed	High Speed	A	B	C	D	E	F	G	Max.	Min.
VC4040	6:1	4L	2.5	.14	.34	.51	4	4-7/8	7-1/2	15/16	2-1/8	2-5/16	1-1/2	3.75	1.53
VC4040	4:1	5L	3.0	.20	.40	.60	4	4-7/8	7-1/2	1-1/16	2-1/16	2-1/4	1-1/2	3.75	1.88
VC5151	7.8:1	4L	3.2	.18	.50	.75	5	6-1/4	9-1/8	1-1/8	2-11/16	2-15/16	1-3/4	4.70	1.58
VC5151	5:1	5L	4.2	.30	.67	1.01	5	6-1/4	9-1/8	1-3/32	2-23/32	2-15/16	1-3/4	4.70	2.10

* Recommended Minimum

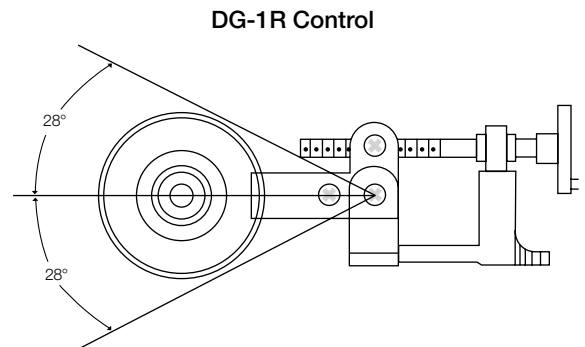
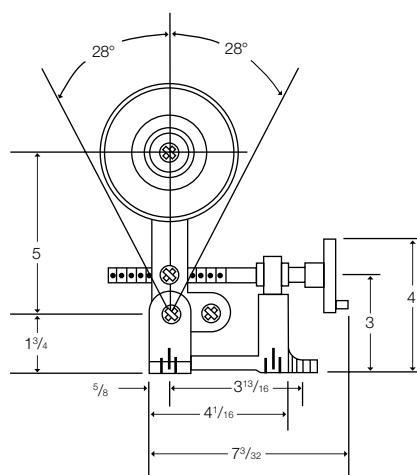
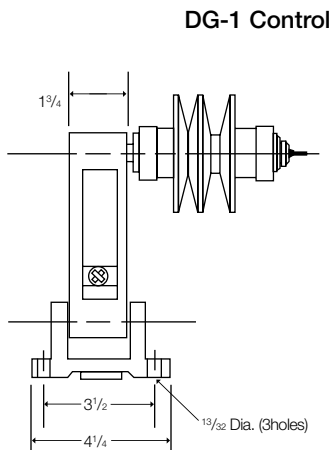

DG-1 control can be changed to DG 1R control or vice-versa by changing the location of the swivel nut.

Fixed Center Drives

Fractional Thru 2 HP

- Maintenance Free
- For use with 'A' (4L) and 'B' (5L) Belts



Drive should be installed as shown in the illustration above.

Selection chart for Type A fixed center Var-A-Cone drives

HP @ 1750	HP @ 1160	DRIVER	DRIVEN	1750 RPM		1160 RPM		CENTER DISTANCE (IN.)							
				MAX	MIN	MAX	MIN	BELT NUMBER							
								AP40	AP46	AP49	AP53	AP57	AP65	AP75	AP85
1/3	1/4	VC57A	VC30	4397	1254	2914	831	16.1	19.1	20.6	22.6	24.6	28.6	33.6	38.6
		VC51A	VC30	4083	1254	2706	831	16.1	19.1	20.6	22.6	24.6	28.6	33.6	38.6
		VC40A	VC30	3590	1019	2379	675	16.5	19.5	21.0	23.0	25.0	29.0	34.0	39.0
		VC30A	VC30	3006	1019	1993	675	16.5	19.5	21.0	23.0	25.0	29.0	34.0	39.0
		VC30A	VC40	2229	853	1477	565	15.9	18.9	20.4	22.5	24.5	28.5	33.5	38.5
		VC30A	VC51	1826	750	1210	497	15.5	18.5	20.0	22.0	24.0	28.0	33.0	38.0
		VC30A	VC57	1859	696	1232	461	15.2	18.2	19.7	21.7	23.7	27.7	32.7	37.7
1/2	1/3	VC57A	VC40	4397	1050	2915	696	15.6	18.6	20.1	22.1	24.1	28.1	33.1	38.1
		VC51A	VC40	4083	1050	2706	696	15.6	18.6	20.1	22.1	24.1	28.1	33.1	38.1
		VC40A	VC40	3590	853	2326	565	15.9	18.9	20.4	22.5	24.5	28.5	33.5	38.5
		VC40A	VC51	2756	750	1826	497	15.5	18.5	20.0	22.0	24.0	28.0	33.0	38.0
		VC40A	VC57	2405	696	1594	461	15.2	18.2	19.7	21.7	23.7	27.7	32.7	37.7
HP @ 1750	HP @ 1160	DRIVER	DRIVEN	1750 RPM		1160 RPM		CENTER DISTANCE (IN.)							
				MAX	MIN	MAX	MIN	BELT NUMBER							
								BP40	BP46	BP49	BP53	BP57	BP65	BP75	BP85
1	1/2	VC57A	VC51	3411	909	2261	603	14.8	17.8	19.3	21.3	23.3	27.3	32.3	37.3
		VC51A	VC51	3025	1012	2005	671	15.4	18.4	19.9	21.9	23.9	27.9	32.9	37.9
		VC51A	VC57	2445	897	1620	595	14.0	17.0	18.5	20.5	22.5	26.5	31.5	36.5
2	1	VC57A	VC57	3797	807	2517	535	14.2	17.2	18.7	20.7	22.8	26.8	31.8	36.8

Fixed Center Drives

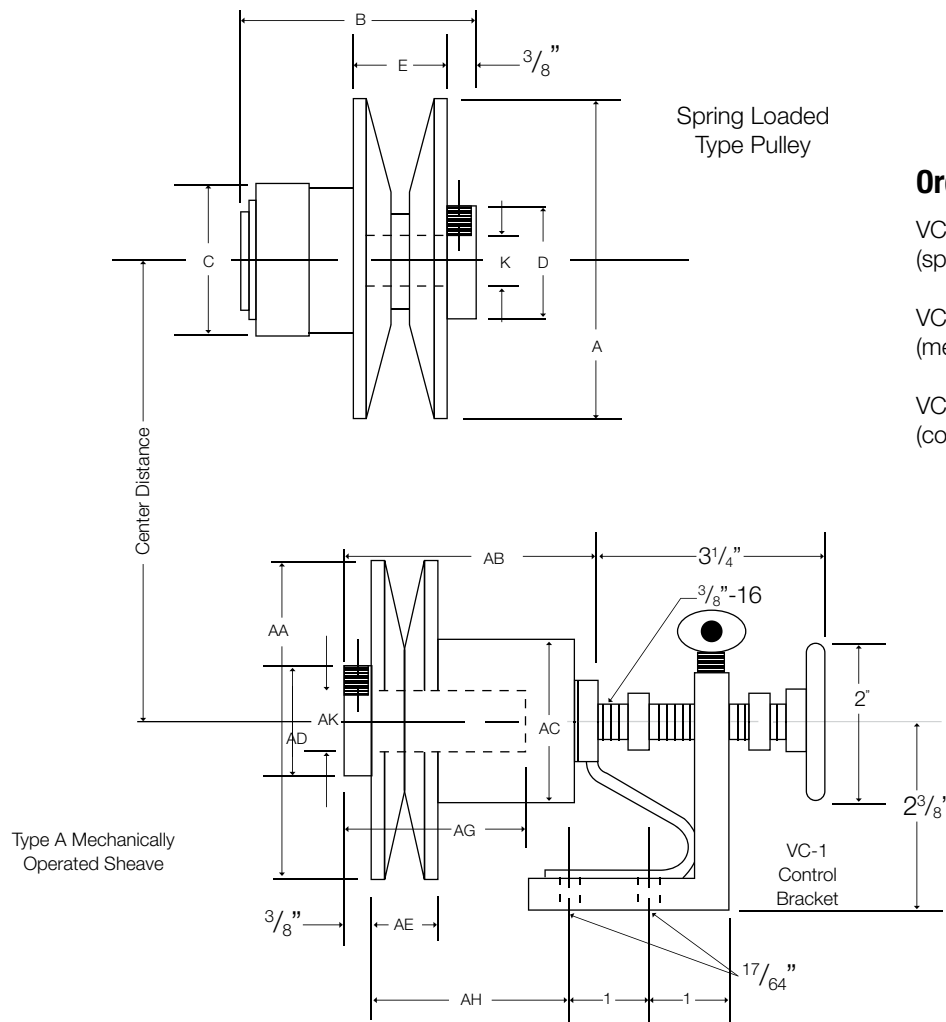

Ordering Examples:

VC30 x 5/8
(spring loaded sheave)

VC40A x 5/8
(mechanically operated sheave)

VC-1
(control bracket)

MODEL NO.	DIMENSIONS IN INCHES					
	A	B	C	D	E*	K
VC30	3.38	2.77	2.13	1.38	1.09	1/2, 5/8, 3/4
VC40	4.00	2.88	2.13	1.38	1.25	1/2, 5/8, 3/4
VC51	5.25	3.69	2.95	1.63	1.46	5/8, 3/4, 7/8, 1
VC57	6.00	3.94	2.95	1.63	1.59	5/8, 3/4, 7/8, 1
	AA	AB*	AC	AD	AE*	AK
VC30A	3.38	4.23	2.00	1.38	1.20	1/2, 5/8, 3/4
VC40A	4.00	4.35	2.00	1.38	1.32	1/2, 5/8, 3/4
VC51A	5.25	5.31	2.75	1.63	1.46	5/8, 3/4, 7/8, 1
VC57A	6.00	5.45	2.75	1.63	1.59	5/8, 3/4, 7/8, 1

BORE	KEYSEAT
1/2	NONE
5/8 - 7/8	3/16 x 3/32
1"	1/4 x 1/8

Furnished with one setscrew.

* Maximum dimension.

Premium V-Belts

AP Belts

Belt Number	Datum Length	Weight	Belt Number	Datum Length	Weight	Belt Number	Datum Length	Weight
AP20	21.3	.2	AP50	51.3	.3	AP81	82.3	.6
AP21	22.3	.2	AP51	52.3	.3	AP82	83.3	.6
AP22	23.3	.2	AP52	53.3	.3	AP83	84.3	.6
AP23	24.3	.2	AP53	54.3	.3	AP84	85.3	.6
AP24	25.3	.2	AP54	55.3	.4	AP85	86.3	.6
AP25	26.3	.2	AP55	56.3	.4	AP86	87.3	.6
AP26	27.3	.2	AP56	57.3	.4	AP87	88.3	.6
AP27	28.3	.2	AP57	58.3	.4	AP88	89.3	.6
AP28	29.3	.2	AP58	59.3	.4	AP89	90.3	.6
AP29	30.3	.2	AP59	60.3	.4	AP90	91.3	.6
AP30	31.3	.2	AP60	61.3	.4	AP91	92.3	.6
AP31	32.3	.2	AP61	62.3	.4	AP92	93.3	.6
AP32	33.3	.2	AP62	63.3	.4	AP93	94.3	.6
AP33	34.3	.2	AP63	64.3	.4	AP94	95.3	.7
AP34	35.3	.2	AP64	65.3	.4	AP95	96.3	.7
AP35	36.3	.2	AP65	66.3	.4	AP96	97.3	.7
AP36	37.3	.2	AP66	67.3	.5	AP97	98.3	.7
AP37	38.3	.2	AP67	68.3	.5	AP98	99.3	.7
AP38	39.3	.2	AP68	69.3	.5	AP100	101.3	.7
AP39	40.3	.3	AP69	70.3	.5	AP103	104.3	.7
AP40	41.3	.3	AP70	71.3	.5	AP105	106.3	.7
AP41	42.3	.3	AP71	72.3	.5	AP110	111.3	.7
AP42	43.3	.3	AP72	73.3	.5	AP112	113.3	.8
AP43	44.3	.3	AP73	74.3	.5	AP116	117.3	.8
AP44	45.3	.3	AP74	75.3	.5	AP120	121.3	.8
AP45	46.3	.3	AP75	76.3	.5	AP128	129.3	.9
AP46	47.3	.3	AP76	77.3	.5	AP136	137.3	1.0
AP47	48.3	.3	AP77	78.3	.5	AP144	145.3	1.0
AP48	49.3	.3	AP78	79.3	.6	AP158	159.3	1.1
AP49	50.3	.3	AP79	80.3	.6	AP173	174.3	1.2
			AP80	81.3	.6	AP180	181.3	1.3

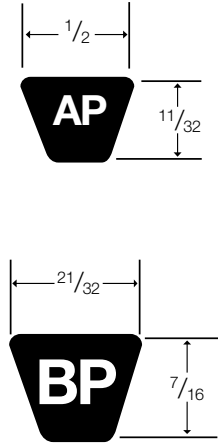

BP Belts

Belt Number	Datum Length	Weight	Belt Number	Datum Length	Weight	Belt Number	Datum Length	Weight	Belt Number	Datum Length	Weight
BP26	27.8	.3	BP55	56.8	.6	BP82	83.8	.9	BP123	124.8	1.3
BP28	29.8	.3	BP56	57.8	.6	BP83	84.8	.9	BP124	125.8	1.3
BP29	30.8	.3	BP57	58.8	.6	BP84	85.8	.9	BP126	127.8	1.4
BP30	31.8	.3	BP58	59.8	.6	BP85	86.8	.9	BP128	129.8	1.4
BP32	33.8	.3	BP59	60.8	.6	BP86	87.8	.9	BP130	131.8	1.4
BP33	34.8	.3	BP60	61.8	.6	BP87	88.8	.9	BP133	134.8	1.4
BP34	35.8	.4	BP61	62.8	.6	BP88	89.8	1.0	BP136	137.8	1.5
BP35	36.8	.4	BP62	63.8	.6	BP89	90.8	1.0	BP140	141.8	1.5
BP36	37.8	.4	BP63	64.8	.7	BP90	91.8	1.0	BP144	145.8	1.6
BP37	38.8	.4	BP64	65.8	.7	BP91	92.8	1.0	BP148	149.8	1.6
BP38	39.8	.4	BP65	66.8	.7	BP92	93.8	1.0	BP150	151.8	1.6
BP39	40.8	.4	BP66	67.8	.7	BP93	93.8	1.0	BP154	155.8	1.7
BP40	41.8	.4	BP67	68.8	.7	BP94	94.8	1.0	BP158	159.8	1.7
BP41	42.8	.4	BP68	69.8	.7	BP95	96.8	1.0	BP162	163.8	1.8
BP42	43.8	.4	BP69	70.8	.7	BP96	97.8	1.0	BP173	174.8	1.9
BP43	44.8	.4	BP70	71.8	.7	BP97	98.8	1.1	BP180	181.8	2.0
BP44	45.8	.5	BP71	72.8	.7	BP98	99.8	1.1	BP191	192.8	2.1
BP45	46.8	.5	BP72	73.8	.8	BP99	100.8	1.1	BP195	196.8	2.1
BP46	47.8	.5	BP73	74.8	.8	BP100	101.8	1.1	BP210	211.8	2.3
BP47	48.8	.5	BP74	75.8	.8	BP103	104.8	1.1	BP225	225.3	2.4
BP48	49.8	.5	BP75	76.8	.8	BP105	106.8	1.1	BP240	240.3	2.6
BP49	50.8	.5	BP76	77.8	.8	BP106	107.8	1.1	BP255	255.3	2.8
BP50	51.8	.5	BP77	78.8	.8	BP108	109.8	1.2	BP270	270.3	2.9
BP51	52.8	.5	BP78	79.8	.9	BP112	113.8	1.2	BP285	285.3	3.1
BP52	53.8	.5	BP79	80.8	.9	BP116	117.8	1.3	BP300	300.3	3.2
BP53	54.8	.6	BP80	81.8	.9	BP118	119.8	1.3	BP315	315.3	3.4
BP54	55.8	.6	BP81	82.8	.9	BP120	121.8	1.3	BP360	360.3	3.9

AP & BP Belts — Outside Length Equals Datum Length + 1".

Interchange

Current Design		Old Designs				Competitors					
Wood's All-Pro		Wood's Pro		Gerbing Quadra-key		Speed Selector		Lovejoy		Hi-Lo	
Model	Max Pitch	Model	Max Pitch	Model	Max Pitch	Model	Max Pitch	Model	Max Pitch	Model	Max Pitch
AP160M	6.25					8816	6.30	2-010	5.80		
AP160M (1922V Belt)	6.30	160N	6.30					21401	5.80		
AP200N	7.87	200N	7.87			7707	6.90				
AP225P	8.80			2303	8.80	8827	7.53	2-030	8.00		
AP260T	10.20			2305	8.80			21903	8.03		
AP260U	10.20	240T	9.45	2905	10.25	7709	8.80			1590	8.62
AP255W	10.00			2907	10.25	8859	9.25				
AP255S	10.00			2910	10.25			2-050	9.70	1711	10.65
AP321W	12.75							22905	9.70		
AP322W	12.75	250W	10.00					2-075	9.70		
AP323W	12.75	250S	10.00			7710	10.20	22907	9.70		
				4410	12.75	8810	10.20				
				4411	12.75	7711- 2.75	10.10				
				4415	12.75	7711-2	10.10	2-1532	10.37	2011	10.65
				4416	12.75	8811-2	10.10	2-3215	10.35		
				4420	12.75			23220	10.35		
				4421	12.75			2-2032	10.37		
				4425	12.75	8813	12.60	24407	12.10		
				4426	12.75			2-100	12.10		
				4430	12.75			24410	12.10		
				4431	12.75	8823	12.60	2-150	12.10		
								2-4415	12.10		
								24420	12.10		
								2-200	12.10		
						8833	12.60	2-250	12.10	2513	12.60
								2-4425	12.10		
								24430	12.10		
								2-300	12.10		
								24430HD	12.10		
								24433HD	12.10		

MS Sheave

Interchange

WOOD'S		EATON (WORTHINGTON)		LOVEJOY		RELIANCE (REEVES)		RELIANCE (DODGE)		SPEED SELECTOR	
Model No.	Max. Pitch	Model No.	Max. Pitch	Model No.	Max. Pitch	Model No.	Max. Pitch	Model No.	Max. Pitch	Model No.	Max. Pitch
MS-58	5.75	-	-	1-007 11407 2600	5.80 5.80 5.80	5675	5.11	14SL	5.63	816	6.30
MS-72	7.25	219S	6.75	1-015 11901	8.00 8.03	7202 97	6.72 7.25	19SL	7.38	707 827	6.90 7.53
MS-77	7.75	20 523S	7.75 9.00	-	-	98	7.75	23SL	9.00	709 859	8.75 9.25
MS-97	9.75	1029S	9.95	1-050 12905 1-075 12907	9.70 9.70 9.70 9.70	9205	9.00	-	-	-	-
MS-127 & MS-127W-HD	12.75	2044S 150	12.60 11.75	1-150 1-4415 3215 1-200 14420 3220 1-250 1-4425 14430 3225	12.10 12.10 11.50 12.10 12.10 11.50 12.10 12.10 12.10 11.50	1320 912-15 1330	12.46 11.75 12.46	44SLN 44SLU	12.36 12.36	711 821 833	10.90 11.60 12.60
MS-975-S	9.40	-	-	1-2032 13220	10.37 10.35	-	-	-	-	-	-
MS-100W	10.00	100	11.75	1-100 14410 3210	12.10 12.10 11.50	1110 912 77	10.77 11.75 13.75	44SLK	12.36	-	-

Interchange

WOOD'S			LOVEJOY			MAUREY			HI-LO		
Model No.	Belt	Max. Pitch	Model No.	Belt	Max. Pitch	Model No.	Belt	Max. Pitch	Model No.	Belt	Max. Pitch
VC30	A	3.35	3403	A	3.13	6325	A or B	3.00	-	-	-
VC40	A	4.00	4005	A	3.75	6400	A or B	3.90	-	-	-
			3405	A	3.13						
			5005A	A	4.75						
VC51	B	5.10	5010	B	4.65	6500	A or B	4.84	30TBR	A	3.13
			5010A	A	4.75						
			3407	A	3.13						
			4007	A	3.75						
VC57	B	5.75	6010	B	5.65	6600	B	5.84	50TBR	B	3.06
			6020	B	5.65	66150	B	5.84			
						66200	B	5.84			

ROTO-CONE SHEAVE INTERCHANGE

WOOD'S		LEWELLEN		LOVEJOY	
Model No.	Max. Pitch	Model No.	Max. Pitch	Model No.	Max. Pitch
RC55	5.25	-	-	245	5.80
RC60	5.75	-	-	-	-
RC75	7.25	408	7.50	301	7.28
RC80	7.75	409	8.75	3030	8.12
RC105	10.38	411	10.75	401	10.60
				402	10.40
				403	10.60
				303	9.60
RC100	9.75			3050	9.60
RC1315	12.75	412/15	11.68	3075	12.50
				3100	12.50
				3150	12.50
RC1330	12.75	-	-	-	-

VPS Sheave

Features

Wood's VPS stationary control adjustable speed sheaves have patented features which eliminate the need for lubrication and assure quick, easy speed adjustment. Exclusive, positive locking collar construction completely eliminates freezing and sticking caused by fretting corrosion.

These drives provide infinite, accurate speed adjustment within their pitch diameter ranges and are accurately balanced for smooth operation and long life.



All VPS sheaves can be easily adjusted by loosening the clamping screws and turning a single adjusting screw.

The table below lists the sizes of VPS sheaves available.

VPS SHEAVES AVAILABLE

Product No.	HP @ 1160	HP @ 1750	Drive Chart	Pitch Diameter		Pitch Ratio	Belt Size	Stock Bores	Approx. Wt. (lbs.)
				Min.	Max.				
VPS7Q	5	7-1/2	NA	3.5	7.0	2:1	1930V	1-1/8	12.5
VPS9R	7-1/2	10	D1-46	4.25	9.0	2.1:1	2530V	1-3/8, 1-5/8	23.5
VPS10R	10	15	D1-46	5.25	10.0	1.9:1	2530V	1-1/4, 1-3/8, 1-5/8	27.5
VPS10W	15	20	D1-47	5.0	10.0	2:1	4430V	1-1/4, 1-3/8, 1-1/2, 1-5/8, 1-7/8	30.0
VPS129W	20	25	D1-48	4.3	12.9	3:1	4430V	1-5/8, 1-7/8	39.0
VPS13Y	30	40	D1-48	6.38	12.75	2:1	4836V	1-7/8, 2-1/8	51.0

Product No. Example: VPS9R sheave with 1-3/8 bore = VPS9R138 (Product No.)

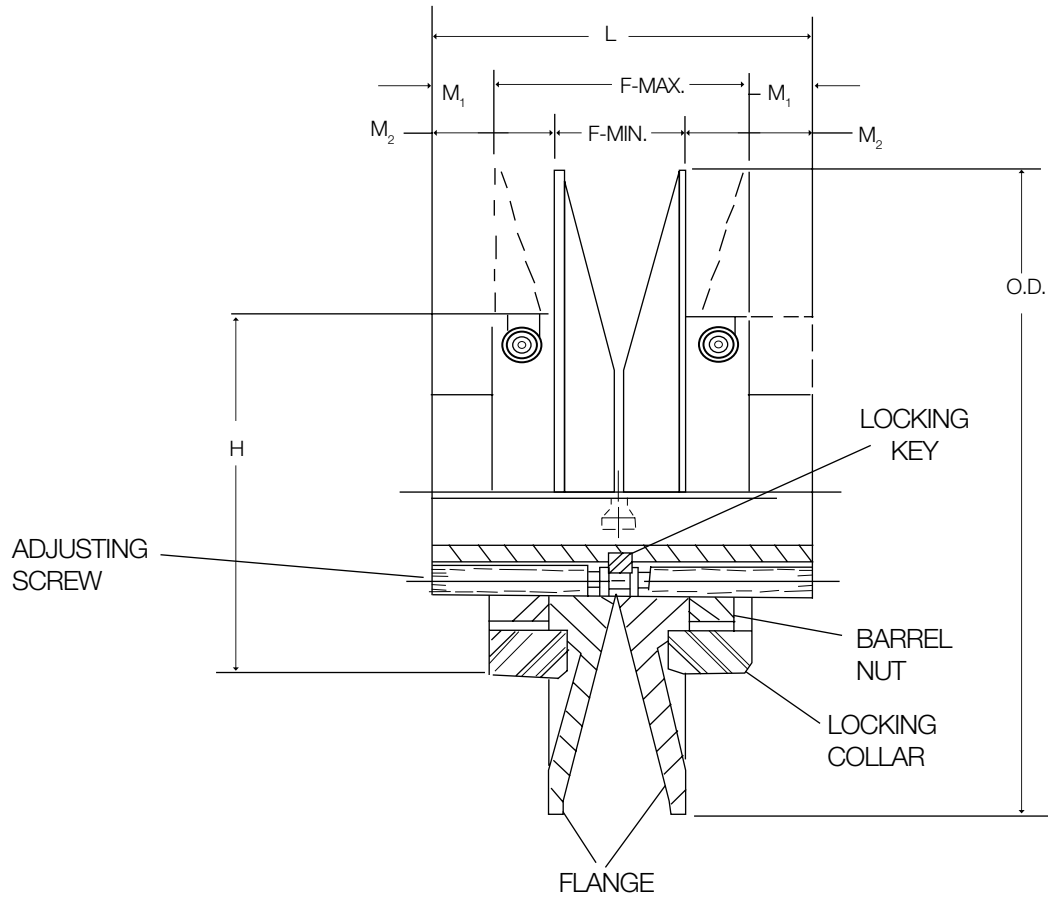

Product No.	O.D.	Max. Bore	F Min.	F Max.	M ₁	M ₂	L	H
VPS7Q	7.25	1-3/8	1-7/16	2-3/8	13/16	1-9/32	4	4-1/8
VPS9R	9.25	1-7/8	1-13/16	3-3/32	57/64	1-17/32	4-7/8	5
VPS10R	10.25	1-7/8	1-13/16	3-3/32	57/64	1-17/32	4-7/8	5
VPS10W	10.25	1-7/8	3	4-11/32	53/64	1-1/2	6	5
VPS129W	13.00	1-7/8	2-31/32	5-1/4	7/8	2-1/64	7	5
VPS13Y	13.00	2-3/8	3.34	5.40	.80	1.83	7	5-1/2

Selection Charts

VPS-9-R DRIVE SELECTION Using 2530V Belt

DRIVEN SPEED		Product Number	Companion Sheave	CENTER DISTANCE IN INCHES AT MAXIMUM AND MINIMUM SPEEDS												
1750 RPM Motor	1160 RPM Motor			VARIABLE SPEED V-BELT NUMBER												
				2530V 531	2530V 550	2530V 595	2530V 630	2530V 670	2530V 690	2530V 730	2530V 750	2530V 790	2530V 890	2530V 990	2530V 1090	2530V 1190
1969	1305	801R	8.0 x 1R-SF	11.2	14.2	16.5	18.3	20.3	21.2	23.3	24.3	26.2	31.2	36.2	41.2	45.0
930	616			14.8	17.8	20.2	21.9	23.9	24.8	26.9	27.9	29.9	34.9	39.9	44.9	48.7
1575	1044	1001R	10.0 x 1R-SF	-	12.6	15.0	16.7	18.7	19.6	21.7	22.7	24.6	29.6	34.6	39.6	43.5
744	493			-	16.1	18.5	20.2	22.3	23.2	25.3	26.3	28.2	33.2	38.2	43.2	47.1
1313	870	1201R	12.0 x 1R-SF	-	-	13.3	15.1	17.1	18.0	20.1	21.1	23.0	28.0	33.0	38.0	41.9
620	411			-	-	16.7	18.5	20.5	21.4	23.6	24.6	26.5	31.5	36.6	41.6	45.5
1212	803	1301R	13.0 x 1R-SF	-	-	12.4	14.2	16.2	17.1	19.3	20.3	22.2	27.2	32.2	37.2	41.1
572	379			-	-	15.7	17.5	19.6	20.5	22.7	23.7	25.6	30.7	35.7	40.8	44.6
1125	746	1401R	14.0 x 1R-SF	-	-	-	13.3	15.4	16.3	18.4	19.4	21.3	26.4	31.4	36.4	40.2
531	352			-	-	-	16.6	18.7	19.6	21.8	22.8	24.7	29.8	34.9	39.9	43.8
984	653	1601R	16.0 x 1R-SF	-	-	-	-	13.5	14.5	16.6	17.7	19.6	24.7	29.7	34.7	38.6
465	308			-	-	-	-	16.7	17.7	19.9	20.9	22.9	28.0	33.1	38.2	42.1

VPS-10-R DRIVE SELECTION Using 2530V Belt

DRIVEN SPEED		Product Number	Companion Sheave	CENTER DISTANCE IN INCHES AT MAXIMUM AND MINIMUM SPEEDS												
1750 RPM Motor	1160 RPM Motor			VARIABLE SPEED V-BELT NUMBER												
				2530V 531	2530V 550	2530V 595	2530V 630	2530V 670	2530V 690	2530V 730	2530V 750	2530V 790	2530V 890	2530V 990	2530V 1090	2530V 1190
2188	1450	801R	8.0 x 1R-SF	10.4	13.4	15.7	17.5	19.5	20.4	22.5	23.5	25.4	30.4	35.4	40.4	44.2
1148	761			14.1	17.1	19.4	21.2	23.2	24.1	26.2	27.2	29.1	34.1	39.1	44.1	48.0
1750	1160	1001R	10.0 x 1R-SF	-	11.8	14.2	15.9	17.9	18.8	20.9	21.9	23.8	28.8	33.8	38.8	42.7
919	609			-	15.4	17.7	19.5	21.5	22.4	24.5	25.5	27.5	32.5	37.5	42.5	46.3
1458	967	1201R	12.0 x 1R-SF	-	-	12.6	14.3	16.3	17.2	19.3	20.3	22.2	27.2	32.2	37.2	41.1
766	508			-	-	16.0	17.8	19.8	20.7	22.8	23.8	25.8	30.8	35.8	40.9	44.7
1346	892	1301R	13.0 x 1R-SF	-	-	-	13.5	15.5	16.4	18.5	19.5	21.4	26.4	31.4	36.4	40.3
707	468			-	-	-	16.9	18.9	19.8	22.0	23.0	24.9	30.0	35.0	40.0	43.9
1250	828	1401R	14.0x 1R-SF	-	-	-	-	14.6	15.6	17.7	18.7	20.6	25.6	30.6	35.6	39.5
656	435			-	-	-	-	18.0	18.9	21.1	22.1	24.0	29.1	34.1	39.2	43.0
1094	725	1601R	16.0 x 1R-SF	-	-	-	-	-	-	15.9	17.0	18.9	23.9	29.0	34.0	37.8
574	381			-	-	-	-	-	-	-	19.2	20.2	22.2	27.3	32.4	37.5

Refer to Table on page D1-53 for additional belts.

VPS-10-W DRIVE SELECTION Using 4430V Belt

DRIVEN SPEED		Product Number	Companion Sheave	CENTER DISTANCE IN INCHES AT MAXIMUM AND MINIMUM SPEEDS													
1750 RPM Motor	1160 RPM Motor			VARIABLE SPEED V-BELT NUMBER													
				4430V 555	4430V 578	4430V 610	4430V 630	4430V 660	4430V 690	4430V 730	4430V 790	4430V 850	4430V 910	4430V 970	4430V 1090	4430V 1320	4430V 1610
2188	1450	801W	8.0 x 1W-SF	13.5	14.7	16.2	17.2	18.7	20.2	22.2	25.2	28.2	31.2	34.2	40.2	51.7	65.5
1094	725			17.4	18.6	20.1	21.1	22.6	24.1	26.1	29.1	32.1	35.1	38.1	44.1	55.6	69.5
2059	1365	851W	8.5 x 1W-SF	13.1	14.3	15.8	16.8	18.3	19.8	21.8	24.8	27.8	30.8	33.8	39.8	51.3	65.2
1029	682			16.9	18.2	19.7	20.7	22.2	23.7	25.7	28.7	31.7	34.7	37.7	43.7	55.2	69.1
1944	1289	901W	9.0 x 1W-SF	12.7	13.9	15.4	16.4	17.9	19.4	21.4	24.4	27.4	30.4	33.5	39.5	51.0	65.0
972	644			16.5	17.8	19.3	20.3	21.8	23.3	25.3	28.3	31.3	34.3	37.3	43.3	54.8	68.7
1842	1221	951W	9.5 x 1W-SF	12.3	13.6	15.1	16.1	17.6	19.1	21.0	24.0	27.0	30.1	33.1	39.1	50.6	64.5
921	611			16.1	17.3	18.9	19.9	21.4	22.9	24.9	27.9	30.9	33.9	36.9	42.9	54.4	68.2
1750	1160	1001W	10.0 x 1W-SF	11.9	13.2	14.7	15.7	17.2	18.7	20.7	23.7	26.7	29.7	32.7	38.7	50.2	64.0
875	580			15.6	16.9	18.4	19.4	20.9	22.5	24.5	27.5	30.5	33.5	36.5	42.5	54.0	67.8
1591	1054	1101W	11.0 x 1W-SF	-	12.4	13.9	14.9	16.4	17.9	19.9	22.9	25.9	28.9	31.9	37.9	49.4	63.2
795	527			-	16.0	17.6	18.6	20.1	21.6	23.6	26.6	29.7	32.7	35.7	41.7	53.2	66.9
1458	967	1201W	12.0 x 1W-SF	-	-	13.1	14.1	15.6	17.1	19.1	22.1	25.1	28.1	31.1	37.1	48.6	62.4
729	483			-	-	16.7	17.7	19.2	20.7	22.7	25.8	28.8	31.8	34.8	40.9	52.4	66.2
1346	892	1301W	13.0 x 1W-SF	-	-	-	13.2	14.7	16.2	18.2	21.2	24.3	27.3	30.3	36.3	47.8	61.6
673	446			-	-	-	16.8	18.3	19.8	21.9	24.9	28.0	31.0	34.0	40.0	51.6	65.4
1250	828	1401W	14.0 x 1W-SF	-	-	-	-	13.9	15.4	17.4	20.4	23.4	26.5	29.5	35.5	47.0	60.8
625	414			-	-	-	-	17.3	18.9	21.0	24.0	27.1	30.1	33.2	39.2	50.8	64.6
1167	773	1501W	15.0 x 1W-SF	-	-	-	-	-	14.5	16.5	19.6	22.6	25.6	28.6	34.7	46.2	60.0
583	387			-	-	-	-	-	18.0	20.0	23.1	26.2	29.2	32.3	38.3	49.9	63.8
1094	725	1601W	16.0 x 1W-SF	-	-	-	-	-	-	15.7	18.7	21.7	24.8	27.8	33.8	45.4	59.2
547	363			-	-	-	-	-	-	19.1	22.2	25.3	28.3	31.4	37.5	49.1	63.0
972	644	1801W	18.0 x 1W-SF	-	-	-	-	-	-	-	16.9	20.0	23.0	26.1	32.1	43.7	57.7
486	322			-	-	-	-	-	-	-	-	19.2	24.4	26.5	29.6	35.7	47.4
875	580	2001W	20.0 x 1W-SF	-	-	-	-	-	-	-	-	18.1	21.2	24.3	30.4	42.0	55.7
438	290			-	-	-	-	-	-	-	-	-	21.4	24.6	27.7	33.9	45.6
795	527	2201W	22.0 x 1W-SF	-	-	-	-	-	-	-	-	17.2	19.3	22.4	28.6	40.3	53.6
398	264			-	-	-	-	-	-	-	-	-	19.3	22.6	25.8	32.0	43.9
729	483	2401W	24.0 x 1W-SF	-	-	-	-	-	-	-	-	-	-	20.5	26.8	38.5	52.5
365	242			-	-	-	-	-	-	-	-	-	-	-	23.7	30.1	42.0

Refer to Table on page D1-53 for additional belts.

Selection Charts

VPS-129-W DRIVE SELECTION Using 4430V Belt

DRIVEN SPEED		Product Number	Companion Sheave	CENTER DISTANCE IN INCHES AT MAXIMUM AND MINIMUM SPEEDS															
1750 RPM Motor	1160 RPM Motor			VARIABLE SPEED V-BELT NUMBER															
				4430V 478	4430V 610	4430V 630	4430V 660	4430V 670	4430V 690	4430V 700	4430V 730	4430V 740	4430V 790	4430V 850	4430V 910	4430V 970	4430V 1090	4430V 1320	4430V 1610
2822	1871	801W	8.0 x 1W-SF	13.1	14.1	15.0	16.6	17.1	18.1	18.7	20.2	20.6	23.2	26.2	29.2	32.3	38.4	50.0	63.5
942	624			19.4	20.9	21.9	23.5	23.9	24.9	25.4	26.9	27.5	30.0	33.0	36.0	39.0	45.0	56.5	70.0
2652	1759	851W	8.5 x 1W-SF	12.1	13.8	14.6	16.1	16.8	17.8	18.3	19.8	20.4	22.8	25.8	28.8	31.9	37.9	49.5	63.0
884	586			18.8	20.4	21.4	22.8	23.4	24.4	24.9	26.4	26.9	29.5	32.5	35.5	38.6	44.6	56.0	69.6
2500	1658	901W	9.0 x 1W-SF	11.6	13.5	14.3	15.8	16.4	17.4	17.8	19.3	19.9	22.4	25.4	28.4	31.5	37.5	49.0	62.5
838	555			18.5	19.9	21.0	22.5	23.0	24.1	24.5	26.0	26.5	29.0	32.0	35.0	38.1	44.1	55.6	69.1
2364	1568	951W	9.5 x 1W-SF	-	13.0	14.0	15.5	16.0	17.0	17.4	18.9	19.6	21.9	25.0	28.0	31.0	37.0	48.5	62.0
792	525			-	19.5	20.6	22.1	22.6	23.6	24.1	25.6	26.1	28.7	31.7	34.7	37.7	43.7	55.2	68.7
2243	1488	1001W	10.0 x 1W-SF	-	12.5	13.5	15.0	15.5	16.5	17.0	18.6	19.0	21.6	24.6	27.6	30.6	36.6	48.2	61.7
752	498			-	19.2	20.2	21.7	22.2	23.2	23.7	25.3	25.6	28.3	31.3	34.3	37.3	43.3	54.8	68.3
2060	1365	1101W	11.0 x 1W-SF	-	-	12.8	14.2	14.8	15.7	16.4	17.9	18.3	20.9	24.0	27.0	30.0	35.9	47.4	60.9
684	453			-	-	19.3	20.8	21.4	22.4	22.9	24.4	25.0	27.4	30.4	33.4	36.4	42.4	54.0	67.5
1882	1249	1201W	12.0 x 1W-SF	-	-	-	13.5	14.1	15.0	15.6	17.1	17.4	20.1	23.1	26.1	29.1	35.2	46.7	60.2
628	416			-	-	-	19.9	20.5	21.4	22.0	23.6	24.0	26.6	29.6	32.8	35.6	41.6	53.2	66.7
1733	1149	1301W	13.0 x 1W-SF	-	-	-	-	-	14.4	14.8	16.3	16.8	19.3	22.3	25.3	28.3	34.4	45.9	59.4
578	383			-	-	-	-	-	-	20.6	21.1	22.6	23.2	25.6	28.6	31.7	34.7	40.8	52.4
1607	1065	1401W	14.0 x 1W-SF	-	-	-	-	-	-	-	15.6	15.7	18.6	21.6	24.6	27.6	33.6	45.2	58.7
537	356			-	-	-	-	-	-	-	-	21.7	22.3	24.8	27.8	30.8	33.8	40.0	51.6
1509	1000	1501W	15.0 x 1W-SF	-	-	-	-	-	-	-	-	15.3	17.7	20.7	23.7	26.7	32.7	44.2	57.7
502	332			-	-	-	-	-	-	-	-	-	21.3	23.9	26.9	29.9	32.9	39.1	50.7
1411	935	1601W	16.0 x 1W-SF	-	-	-	-	-	-	-	-	-	16.8	19.8	22.8	25.8	31.8	43.3	56.6
470	312			-	-	-	-	-	-	-	-	-	-	22.9	26.0	29.1	32.2	38.3	49.9
1259	835	1801W	18.0 x 1W-SF	-	-	-	-	-	-	-	-	-	-	18.1	21.1	24.2	30.2	41.8	55.3
419	277			-	-	-	-	-	-	-	-	-	-	-	24.2	27.2	30.3	36.5	48.2
1129	748	2001W	20.0 x 1W-SF	-	-	-	-	-	-	-	-	-	-	-	19.4	22.4	28.5	40.7	53.7
376	250			-	-	-	-	-	-	-	-	-	-	-	-	25.4	28.4	34.6	46.4
1030	683	2201W	22.0 x 1W-SF	-	-	-	-	-	-	-	-	-	-	-	-	20.8	26.9	38.6	52.2
342	227			-	-	-	-	-	-	-	-	-	-	-	-	-	26.5	32.8	44.6
941	624	2401W	24.0 x 1W-SF	-	-	-	-	-	-	-	-	-	-	-	-	-	25.1	36.9	50.5
314	208			-	-	-	-	-	-	-	-	-	-	-	-	-	-	31.2	42.8
806	534	2801W	28.0 x 1W-SE	-	-	-	-	-	-	-	-	-	-	-	-	-	-	33.0	47.8
269	178			-	-	-	-	-	-	-	-	-	-	-	-	-	-	-	38.9

VPS-13-Y DRIVE SELECTION Using 4836V Belt

DRIVEN SPEED		Product Number	Companion Sheave	CENTER DISTANCE IN INCHES AT MAXIMUM AND MINIMUM SPEEDS										
1750 RPM Motor	1160 RPM Motor			VARIABLE SPEED V-BELT NUMBER										
				4836V 670	4836V 710	4836V 800	4836V 850	4836V 900	4836V 950	4836V 1000	4836V 1060	4836V 1120	4836V 1180	4836V 1250
2231	1479	1001Y	10.0 x 1Y-F	15.6	17.6	22.1	24.6	27.1	29.6	32.1	35.1	38.1	41.1	44.6
1117	740			20.6	22.6	27.1	29.6	32.1	34.6	37.1	40.1	43.1	46.1	49.6
2028	1345	1101Y	11.0 x 1Y-F	14.8	16.8	21.3	23.8	26.3	28.8	31.3	34.3	37.3	40.3	43.8
1015	673			19.7	21.7	26.3	28.8	31.3	33.8	36.3	39.3	42.3	45.3	48.8
1859	1233	1201Y	12.0 x 1Y-F	14.1	16.1	20.6	23.1	25.6	28.1	30.6	33.6	36.6	39.6	43.1
930	617			18.9	20.9	25.4	27.9	30.4	33.0	35.5	38.5	41.5	44.5	48.0
1594	1056	1401Y	14.0 x 1Y-F	-	14.5	19.0	21.5	24.0	26.5	29.0	32.0	35.0	38.0	41.5
798	529			-	19.1	23.7	26.2	28.7	31.3	33.8	36.8	39.8	42.8	46.3
1395	924	1601Y	16.0 x 1Y-F	-	-	17.3	19.9	22.4	24.9	27.4	30.4	33.4	36.4	39.9
698	463			-	-	21.9	24.5	27.0	29.5	32.1	35.1	38.1	41.1	44.7
1240	822	1801Y	18.0 x 1Y-F	-	-	-	18.2	20.7	23.2	25.7	28.7	31.8	34.8	38.3
620	411			-	-	-	22.6	25.2	27.8	30.3	33.4	36.4	39.4	43.0
1116	740	2001Y	20.0 x 1Y-F	-	-	-	-	18.9	21.5	24.0	27.0	30.1	33.1	36.6
558	370			-	-	-	-	-	23.3	25.9	28.5	31.5	34.6	37.7
930	616	2401Y	24.0 x 1Y-F	-	-	-	-	-	-	20.4	23.5	26.6	29.6	33.2
465	308			-	-	-	-	-	-	-	24.6	27.7	30.9	34.0
744	493	3001Y	30.0 x 1Y-F	-	-	-	-	-	-	-	-	-	23.9	27.6
372	247			-	-	-	-	-	-	-	-	-	-	28.0

Refer to Table on page D1-53 for additional belts.

Dimensions

Wood's QS "Quick-Slide" Motor Bases are of heavy-duty welded steel construction. A unique feature of the QS Motor Base is the provision for releasing the adjusting screw, permitting the motor to be moved freely and quickly. Its slender construction makes it suitable for applications where space is at a premium.

For ceiling mounting, use MBA base, page D1-50.

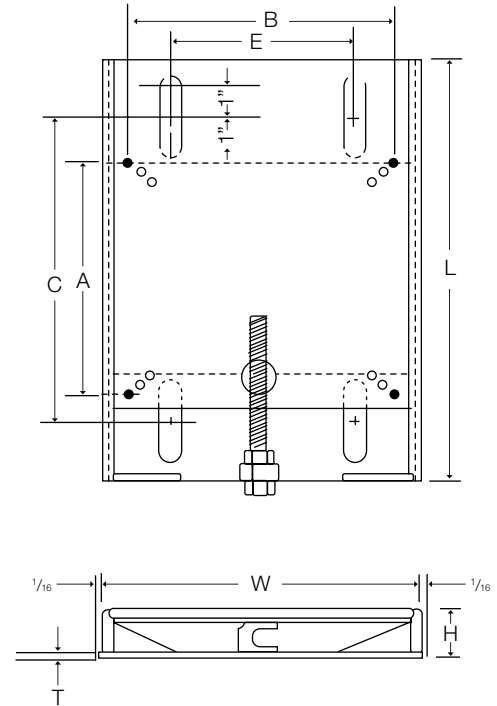
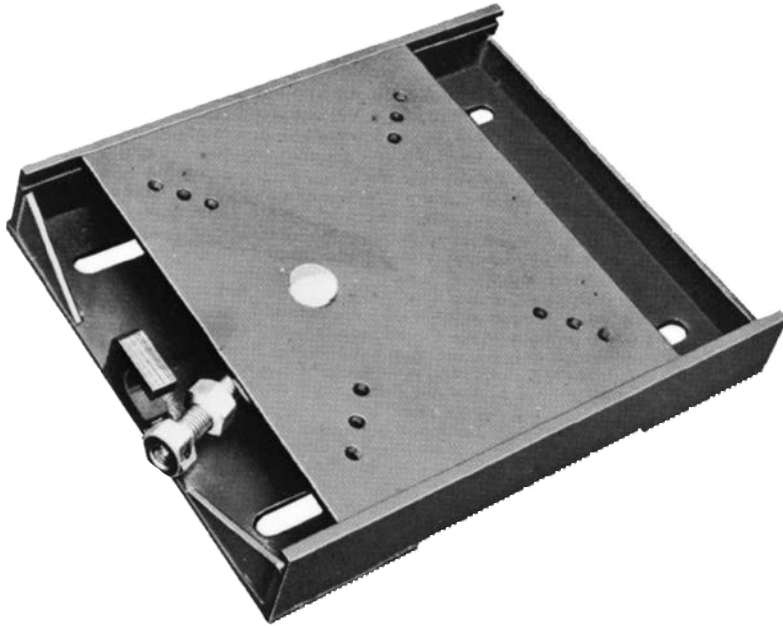

Product No.	NEMA Motor Frame Number	DIMENSIONS—INCHES								Amount of Movement, inches	No. & Size of Cap Screws for Motor, inches	No. & Size of Floor Bolts,* inches	Wt. Lbs.
		A	B	C	E	H	L	T	W				
QS1A	143	5-1/2	4	9-5/8	6-1/8	1-5/8	14	1/4	10-3/8	4-1/2	4-5/16	4-5/8	17.5
QS1B	145	5-1/2	5	9-5/8	6-1/8	1-5/8	14	1/4	10-3/8	4-1/2	4-5/16	4-5/8	17.5
QS1A	182	7-1/2	4-1/2	9-5/8	6-1/8	1-5/8	14	1/4	10-3/8	4-1/2	4-3/8	4-5/8	17.5
QS1B	184	7-1/2	5-1/2	9-5/8	6-1/8	1-5/8	14	1/4	10-3/8	4-1/2	4-3/8	4-5/8	17.5
QS1A	213	8-1/2	5-1/2	9-5/8	6-1/8	1-5/8	14	1/4	10-3/8	4-1/2	4-3/8	4-5/8	17.5
QS1B	215	8-1/2	7	9-5/8	6-1/8	1-5/8	14	1/4	10-3/8	4-1/2	4-3/8	4-5/8	17.5
QS2A	254	10	8-1/4	12-3/8	9	1-21/32	16-3/4	1/4	13-1/4	6	4-1/2	4-5/8	30.5
QS2A	256	10	10	12-3/8	9	1-21/32	16-3/4	1/4	13-1/4	6	4-1/2	4-5/8	30.5
QS2A	284	11	9-1/2	12-3/8	9	1-21/32	16-3/4	1/4	13-1/4	6	4-1/2	4-5/8	30.5
QS3A	286	11	11	15-1/8	12	1-21/32	19-1/2	1/4	16-1/4	6	4-1/2	4-5/8	42.0
QS3A	324	12-1/2	10-1/2	15-1/8	12	1-21/32	19-1/2	1/4	16-1/4	6	4-5/8	4-5/8	42.0
QS3B	326	12-1/2	12	15-1/8	12	1-21/32	19-1/2	1/4	16-1/4	6	4-5/8	4-5/8	43.5
QS3B	364	14	11-1/4	15-1/8	12	1-21/32	19-1/2	1/4	16-1/4	6	4-5/8	4-5/8	43.5
QS3A	365	14	12-1/4	15-1/8	12	1-21/32	19-1/2	1/4	16-1/4	6	4-5/8	4-5/8	42.0

*Floor bolts not furnished

MBA Motor Bases

Dimensions

Wood's MBA Motor Bases feature heavy-duty cast iron construction for use with all types of variable speed drives. The base can be mounted in any position, and will accommodate NEMA motor frames 48 through 405. For applications requiring an angled motor base, the MBA base is designed to permit up to a 12° angle.

MBA MOTOR BASE DIMENSIONS

PRODUCT NO.	NEMA MOTOR FRAME NO.	A	B	ALL DIMENSIONS - INCHES			F	G	H	L	M	T	W	J TRAVEL EACH WAY
				C	D	E								
MB5*	48	4-1/4	2-3/4	16	8	7-5/8	2-13/16	13/16	3-3/8	18	20-1/2	9/16	9-1/2	4-15/16
	56	4-7/8	3	16	8	7-5/8	2-13/16	13/16	3-3/8	18	20-1/2	9/16	9-1/2	4-5/8
	143	5-1/2	4	16	8	7-5/8	2-13/16	13/16	3-3/8	18	20-1/2	9/16	9-1/2	4-5/16
	145	5-1/2	5	16	8	7-5/8	2-13/16	13/16	3-3/8	18	20-1/2	9/16	9-1/2	4-5/16
MBA15	143	5-1/2	4	15	7-1/2	9-5/16	2-13/16	1-1/4	3-3/8	17-1/2	21	7/16	10-1/2	5-3/4
	145	5-1/2	5	15	7-1/2	9-5/16	2-13/16	1-1/4	3-3/8	17-1/2	21	7/16	10-1/2	5-1/2
	182	7-1/2	4-1/2	15	7-1/2	9-5/16	2-13/16	1-1/4	3-3/8	17-1/2	21	7/16	10-1/2	4-5/8
	184	7-1/2	5-1/2	15	7-1/2	9-5/16	2-13/16	1-1/4	3-3/8	17-1/2	21	7/16	10-1/2	4-3/8
	213	8-1/2	5-1/2	15	7-1/2	9-5/16	2-13/16	1-1/4	3-3/8	17-1/2	21	7/16	10-1/2	3-7/8
	215	8-1/2	7	15	7-1/2	9-5/16	2-13/16	1-1/4	3-3/8	17-1/2	21	7/16	10-1/2	3-1/4
MBA25	254	10	8-1/4	18-3/8	9-3/16	13-9/16	5	1-1/2	5	25	30-5/16	7/8	15	6-1/4
	256	10	10	18-3/8	9-3/16	13-9/16	5	1-1/2	5	25	30-5/16	7/8	15	5-9/16
	284	11	9-1/2	18-3/8	9-3/16	13-9/16	5	1-1/2	5	25	30-5/16	7/8	15	5-1/4
	286	11	11	18-3/8	9-3/16	13-9/16	5	1-1/2	5	25	30-5/16	7/8	15	4-9/16
MBA30	324	12-1/2	10-1/2	20-1/4	10-1/8	14-1/2	5	1-1/2	5-11/16	23-7/8	28-5/8	3/4	16	4-9/16
	326	12-1/2	12	20-1/4	10-1/8	14-1/2	5	1-1/2	5-11/16	23-7/8	28-5/8	3/4	16	4
	364	14	11-1/4	20-1/4	10-1/8	14-1/2	5	1-1/2	5-11/16	23-7/8	28-5/8	3/4	16	3-1/2
	365	14	12-1/4	20-1/4	10-1/8	14-1/2	5	1-1/2	5-11/16	23-7/8	28-5/8	3/4	16	3-1/16
MB40*	404	16	12-1/4	24-1/2	12-1/4	17-1/2	6-3/4	1-1/2	6-1/2	28	33	7/8	19-3/16	4-5/16
	405	16	13-3/4	24-1/2	12-1/4	17-1/2	6-3/4	1-1/2	6-1/2	28	33	7/8	19-3/16	4-5/16

PRODUCT NO.	NEMA MOTOR FRAME NO.	SIZE OF 4 MOTOR CAPSCR.†	SIZE OF 4 FLOOR BOLTS†	WT. (LBS.)
MB5*	48	5/16	3/8	30
	56	5/16	3/8	30
	143	5/16	3/8	30
	145	5/16	3/8	30
MBA15	143	5/16	3/8	32
	145	5/16	3/8	32
	182	3/8	3/8	32
	184	3/8	3/8	32
	213	3/8	3/8	32
MBA25	254	1/2	5/8	105
	256	1/2	5/8	105
	284	1/2	5/8	105
	286	1/2	5/8	105
MBA30	324	5/8	5/8	115
	326	5/8	5/8	115
	364	5/8	5/8	115
	365	5/8	5/8	115
MB40*	404	3/4	5/8	200
	405	3/4	5/8	200

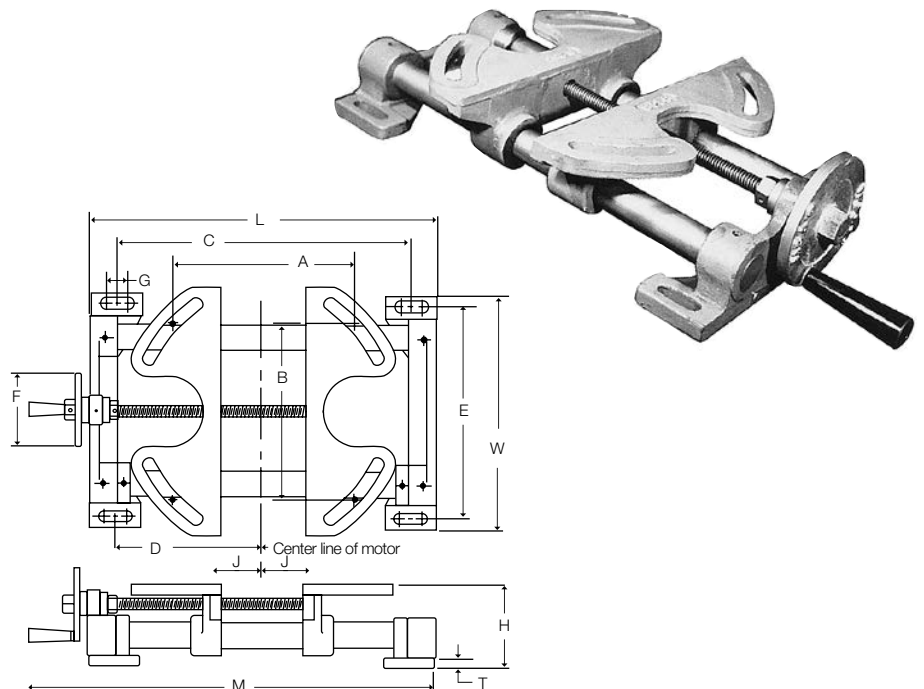

† Cap screw & bolts not furnished.

* The MB5 & MB40 are not designed for angle mounting.

Dimensions

Wood's MC Motor Bases are of heavy duty welded steel construction. This base is equipped with a hand-wheel for maximum ease of adjustment. For applications requiring an angled Motor Base, the motor base must be ordered with the drilling at the proper angle. Refer to page D1—22 for information on how to determine the proper angle for mounting the Motor Base.

This base is designed for floor mounting only. For ceiling mounting, use MBA base, page D1—50.

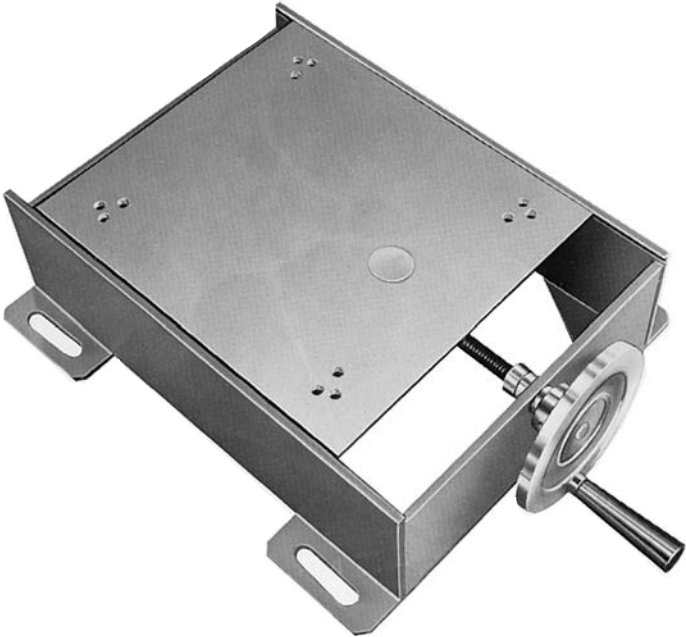
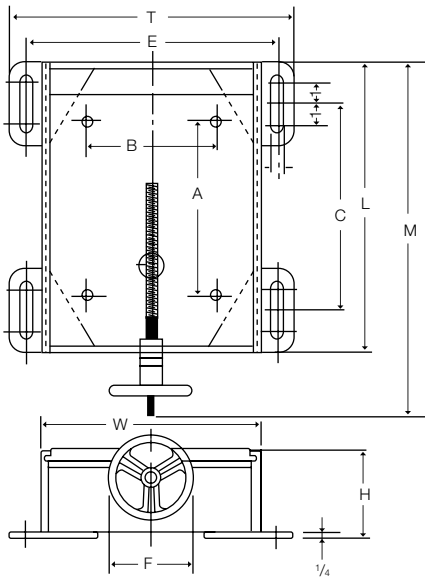

DO NOT use the MC-3 motor base for applications with MCS sheaves. For these applications use MBA motor base.

Motion Control Base Number	NEMA Motor Frame Number	DIMENSIONS - INCHES										Amount of Movement, Inches	No. & Size of Cap Screws for Motor, Inches	No. & Size of Floor Bolts,* Inches	Wt. Lbs.
		A	B	C	E	F	H	L	M	T	W				
MC-1A	143	5-1/2	4	9-1/2	12	4	4-1/4	14	17-5/8	13-1/2	10-3/8	6	4-5/16	4-5/8	25
MC-1B	145	5-1/2	5	9-1/2	12	4	4-1/4	14	17-5/8	13-1/2	10-3/8	6	4-5/16	4-5/8	25
MC-1A	182	7-1/2	4-1/2	9-1/2	12	4	4-1/4	14	17-5/8	13-1/2	10-3/8	6	4-3/8	4-5/8	25
MC-1B	184	7-1/2	5-1/2	9-1/2	12	4	4-1/4	14	17-5/8	13-1/2	10-3/8	6	4-3/8	4-5/8	25
MC-1A	213	8-1/2	5-1/2	9-1/2	12	4	4-1/4	14	17-5/8	13-1/2	10-3/8	6	4-3/8	4-5/8	25
MC-1B	215	8-1/2	7	9-1/2	12	4	4-1/4	14	17-5/8	13-1/2	10-3/8	6	4-3/8	4-5/8	25
MC-2A	254	10	8-1/4	13-3/4	15-1/8	6	5-9/32	18-1/4	24	16-5/8	13-1/4	8	4-1/2	4-5/8	50
MC-2A	256	10	10	13-3/4	15-1/8	6	5-9/32	18-1/4	24	16-5/8	13-1/4	8	4-1/2	4-5/8	50
MC-2A	284	11	9-1/2	13-3/4	15-1/8	6	5-9/32	18-1/4	24	16-5/8	13-1/4	8	4-1/2	4-5/8	50
MC-3A	286	11	11	20	18-1/8	6	5-9/32	24-1/2	30-1/4	19-5/8	16-1/4	10	4-1/2	4-5/8	66
MC-3A	324	12-1/2	10-1/2	20	18-1/8	6	5-9/32	24-1/2	30-1/4	19-5/8	16-1/4	10	4-5/8	4-5/8	66
MC-3B	326	12-1/2	12	20	18-1/8	6	5-9/32	24-1/2	30-1/4	19-5/8	16-1/4	10	4-5/8	4-5/8	66
MC-3B	364	14	11-1/4	20	18-1/8	6	5-9/32	24-1/2	30-1/4	19-5/8	16-1/4	10	4-5/8	4-5/8	66
MC-3A	365	14	12-1/4	20	18-1/8	6	5-9/32	24-1/2	30-1/4	19-5/8	16-1/4	10	4-5/8	4-5/8	66

*Floor bolts not furnished.

Variable Speed Belts

Dimensions

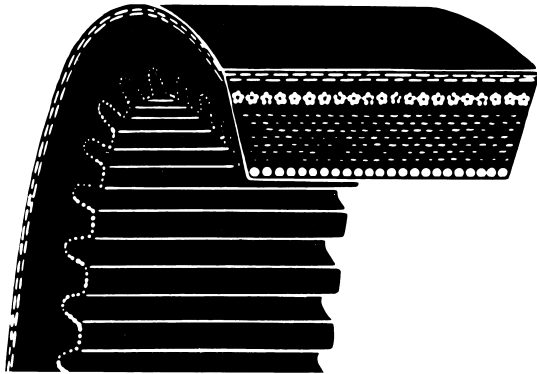

All Wood's Variable Speed Belts are precision molded to assure a completely uniform cross section. This allows even tracking and smooth running, without any vibration problems, extending the life of the belt, bearings, sheaves and other drive components.

These belts are built thin with precision, uniform notches on the underside for maximum lengthwise flexibility. Therefore, they can be used on small pulley drives without sacrificing any gripping action or cross-rigidity. Because of their arched construction, Variable Speed Belts have amazing crosswise rigidity that resists distortion under speed change tensions.

The aramid fiber tensile members of the Variable Speed Belts are dimensionally stable, therefore extending belt life. The rubber used in these belts is especially compounded for a strong resistance to the harmful, belt-damaging effects of heat and oil. Also, they are static conducting.

BELT CODE EXPLANATION

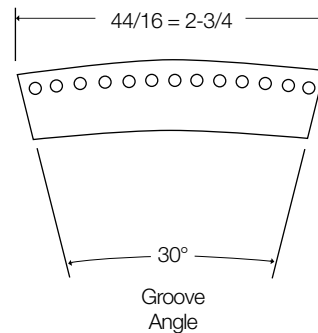
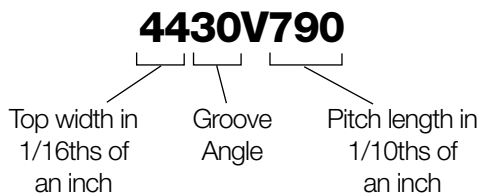

1422 V Belts [M]

Belt No.	Pitch Length	Wt.
*1422V235	23.5	.29
*1422V240	24.0	.29
*1422V270	27.0	.32
*1422V290	29.0	.35
*1422V300	30.0	.36
*1422V330	33.0	.39
*1422V340	34.0	.40
*1422V360	36.0	.43
*1422V400	40.0	.47
*1422V420	42.0	.50
*1422V440	44.0	.52
*1422V460	46.0	.55
*1422V466	46.6	.55
*1422V470	47.0	.55
*1422V480	48.0	.57
*1422V540	54.0	.64
*1422V600	60.0	.72
*1422V660	66.0	.75
*1422V720	72.0	.82
*1422V780	78.0	.89

1922 V Belts [N]

Belt No.	Pitch Length	Wt.
1922V256	25.6	.48
1922V277	27.7	.52
1922V282	28.2	.53
1922V298	29.8	.56
1922V302	30.2	.57
1922V321	32.1	.60
1922V332	33.2	.62
1922V338	33.8	.63
1922V363	36.3	.68
1922V381	38.1	.71
1922V386	38.6	.72
1922V403	40.3	.75
1922V417	41.7	.78
1922V426	42.6	.79
1922V443	44.3	.83
1922V454	45.4	.85
1922V460	46.0	.86
1922V484	48.4	.90
1922V526	52.6	.98
*1922V544	54.4	1.01

1922 V Belts [N]

Belt No.	Pitch Length	Wt.
*1922V604	60.4	1.12
*1922V630	63.0	1.17
*1922V646	64.6	1.20
*1922V666	66.6	1.23
*1922V686	68.6	1.37
*1922V706	70.6	1.40
*1922V721	72.1	1.33
*1922V726	72.6	1.44
*1922V751	75.1	1.39
*1922V756	75.6	1.40
*1922V806	80.6	1.60
*1922V846	84.6	1.68
*1922V891	89.1	1.77
*1922V966	96.6	1.92
*1922V1146	114.6	2.27

*These sizes are machine cut notch with envelope construction.
All others are molded notch, rubber edge construction.

Variable Speed Belts

Dimensions

1930 V Belts [Q]

Product No.	Pitch Length	Weight
1930V366	36.6	.86
1930V400	40.0	.93
1930V425	42.5	.99
1930V431	43.1	1.00
1930V450	45.0	1.05
1930V491	49.1	1.14
1930V500	50.0	1.16
1930V541	54.1	1.25
1930V560	56.0	1.30
1930V591	59.1	1.37
1930V600	60.0	1.39
1930V641	64.1	1.48
1930V691	69.1	1.60
1930V991	99.1	2.28
1930V1091	109.1	2.51

2322 V Belts [P]

Product No.	Pitch Length	Weight
2322V329	32.9	1.08
2322V347	34.7	1.14
2322V364	36.4	1.08
2322V384	38.4	1.14
2322V396	39.6	1.17
2322V421	42.1	1.24
2322V434	43.4	1.28
2322V441	44.1	1.30
2322V461	46.1	1.36
2322V481	48.1	1.42
2322V521	52.1	1.53
2322V541	54.1	1.59
2322V601	60.1	1.76
2322V621	62.1	1.82
2322V661	66.1	1.94
2322V681	68.1	2.00
2322V701	70.1	2.05
2322V721	72.1	2.11
2322V801	80.1	2.34
2322V826	82.6	2.42
2322V846	84.6	2.47
2322V886	88.6	2.59
*2322V921	92.1	2.71
*2322V1001	100.1	2.94
*2322V1061	106.1	3.12

*These sizes are machine cut notch with envelope construction. All others are molded notch, rubber edge construction.

2530 V Belts [R]

Product No.	Pitch Length	Weight
2530V300	30.0	.84
2530V335	33.5	1.24
2530V490	49.0	2.01
2530V500	50.0	2.07
2530V530	53.0	2.17
2530V550	55.0	2.25
2530V575	57.5	2.35
2530V595	59.5	2.43
2530V600	60.0	2.45

2530 V Belts [R] (Continued)

Product No.	Pitch Length	Weight
2530V610	61.0	2.49
2530V630	63.0	2.57
2530V660	66.0	2.67
2530V670	67.0	2.73
2530V690	69.0	2.82
2530V700	70.0	2.86
2530V730	73.0	2.98
2530V750	75.0	3.06
2530V790	79.0	3.22
2530V840	84.0	3.42
2530V850	85.0	3.46
2530V890	89.0	3.62
2530V934	93.4	3.81
2530V990	99.0	4.02
2530V1090	109.0	4.42
2530V1190	119.0	4.83

2926 V Belts [T]

Product No.	Pitch Length	Weight
2926V366	36.6	1.47
2926V400	40.0	1.60
2926V426	42.6	1.70
2926V471	47.1	1.88
2926V477	47.7	1.90
2926V486	48.6	1.93
2926V491	49.1	1.95
2926V521	52.1	2.07
2926V534	53.4	2.12
2926V546	54.6	2.17
2926V574	57.4	2.28
2926V586	58.6	2.32
2926V606	60.6	2.40
2926V616	61.6	2.44
2926V636	63.6	2.52
2926V646	64.6	2.56
2926V666	66.6	2.64
2926V686	68.6	2.72
2926V706	70.6	2.80
2926V726	72.6	2.87
2926V776	77.6	3.07
2926V786	78.6	3.11
2926V834	83.4	3.29
2926V856	85.6	3.38
2926V891	89.1	3.52
2926V906	90.6	3.58
2926V921	92.1	3.64
2926V966	96.6	3.81
2926V1006	100.6	3.97
2926V1026	102.6	3.57
2926V1086	108.6	3.78
2926V1106	110.6	3.84
2926V1146	114.6	3.98

3230 HV Belts [S]

Product No.	Pitch Length	Weight
3230HV528	52.8	3.13
3230HV546	54.6	3.22
3230HV553	55.3	3.28
3230HV570	57.0	3.38
3230HV585	58.5	3.47
3230HV603	60.3	3.57
3230HV613	61.3	3.63
3230HV620	62.0	3.67
3230HV626	62.6	3.69
3230HV644	64.4	3.81
3230HV685	68.5	4.05
3230HV702	70.2	4.15
3230HV723	72.3	4.27
3230HV821	82.1	4.85
3230HV856	85.6	5.05
3230HV931	93.1	5.49
3230HV960	96.0	5.66
3230HV1060	106.0	6.25

4430 V Belts [W]

Product No.	Pitch Length	Weight
4430V510	51.0	4.05
4430V530	53.0	4.20
4430V548	54.8	4.35
4430V555	55.5	4.40
4430V560	56.0	4.44
4430V570	57.0	4.51
4430V578	57.8	4.58
4430V600	60.0	4.75
4430V610	61.0	4.82
4430V630	63.0	4.98
4430V652	65.2	5.10
4430V660	66.0	5.21
4430V670	67.0	5.29
4430V690	69.0	5.44
4430V700	70.0	5.52
4430V710	71.0	5.60
4430V718	71.8	5.66
4430V730	73.0	5.76
4430V740	74.0	5.84
4430V750	75.0	5.91
4430V760	76.0	5.99
4430V780	78.0	6.10
4430V790	79.0	6.23
4430V800	80.0	6.30
4430V850	85.0	6.69
4430V900	90.0	7.08
4430V910	91.0	7.16
4430V930	93.0	7.31
4430V950	95.0	7.47
4430V970	97.0	7.63
4430V1000	100.0	7.86
4430V1030	103.0	8.09
4430V1060	106.0	8.33
4430V1090	109.0	8.56
4430V1120	112.0	8.79
4430V1150	115.0	9.03
4430V1180	118.0	9.26
4430V1250	125.0	9.90
4430V1320	132.0	10.35

4430 V Belts [W] (Continued)

Product No.	Pitch Length	Weight
4430V1410	141.0	10.55
4430V1460	146.0	10.93
4430V1610	161.0	12.04

4836 V Belts [Y]

Product No.	Pitch Length	Weight
4836V608	60.8	5.12
4836V618	61.8	5.54
4836V655	65.5	5.82
4836V670	67.0	5.99
4836V710	71.0	6.35
4836V800	80.0	7.16
4836V850	85.0	7.68
4836V900	90.0	8.04
4836V950	95.0	8.50
4836V1000	100.0	9.75
4836V1060	106.0	10.34
4836V1120	112.0	10.93
4836V1180	118.0	11.52
4836V1250	125.0	12.20

Note: Longer 4836 V belts are available on special order. Contact factory for availability.

Note: The Variable Speed Belts listed on these pages are only those used with Wood's stock Variable Speed Drives. For other available belts, refer to catalog WLP or consult the factory.

Wide Range Companion Sheaves

Dimensions

The companion sheaves for the motion control variable speed driver sheaves are made to accommodate Sure-Grip Bushings for ease of installation. The tables below list the dimensions for each.

PRODUCT NO.	Pitch Dia.	O.D.	BUSHING	TYPE	E	K	L	M	WT.
SINGLE "M" GROOVE FOR 1422V BELT F = 1-1/8 GROOVE TOP WIDTH = 7/8									
531M	5.3	5.45	SH	D1	9/32	9/32	1-1/4	5/32	4.4
581M	5.8	5.95	SH	D1	9/32	9/32	1-1/4	5/32	5.3
681M	6.8	6.95	SH	D2	9/32	9/32	1-1/4	5/32	5.3
781M	7.8	7.95	SH	D2	9/32	9/32	1-1/4	5/32	6.5
881M	8.8	8.95	SH	D2	9/32	9/32	1-1/4	5/32	7.8

SINGLE "N" GROOVE FOR 1922V BELT F = 1-7/16 GROOVE TOP WIDTH = 1-3/16									
561N	5.6	5.82	SK	D1	19/32	1/8	1-7/8	5/32	6.8
661N	6.6	6.82	SK	D1	19/32	1/8	1-7/8	5/32	9.7
761N	7.6	7.82	SK	D2	19/32	1/8	1-7/8	5/32	10.4
861N	8.6	8.82	SK	D2	19/32	1/8	1-7/8	5/32	12.0
961N	9.6	9.82	SK	D2	19/32	1/8	1-7/8	5/32	13.8
1061N	10.6	10.82	SK	D2	19/32	1/8	1-7/8	5/32	14.8
1161N	11.6	11.82	SK	D2	19/32	1/8	1-7/8	5/32	12.5
1361N	13.6	13.82	SK	D3	19/32	1/8	1-7/8	5/32	19.4
1561N	15.6	15.82	SK	D3	19/32	1/8	1-7/8	5/32	22.1
1761N	17.6	17.82	SK	D3	19/32	1/8	1-7/8	5/32	25.2

SINGLE "P" GROOVE FOR 2322V BELT F = 1-11/16 GROOVE TOP WIDTH = 1-7/16									
661P	6.6	6.85	SK	D1	1/2	7/32	1-7/8	5/16	6.8
731P	7.3	7.50	SK	D1	1/2	7/32	1-7/8	5/16	9.7
761P	7.6	7.85	SK	D1	1/2	7/32	1-7/8	5/16	9.9
861P	8.6	8.85	SK	D2	1/2	7/32	1-7/8	5/16	13.3
961P	9.6	9.85	SK	D2	1/2	7/32	1-7/8	5/16	12.8
1081P	10.8	11.05	SK	D2	1/2	7/32	1-7/8	5/16	15.0
1181P	11.8	12.00	SK	D3	1/2	7/32	1-7/8	5/16	15.7
1381P	13.8	14.00	SK	D3	1/2	7/32	1-7/8	5/16	19.4
1581P	15.8	16.00	SK	D3	1/2	7/32	1-7/8	5/16	22.1
1781P	17.8	18.00	SK	D3	1/2	7/32	1-7/8	5/16	25.2

SINGLE "R" GROOVE FOR 2530V BELT F = 1-15/16 GROOVE TOP WIDTH = 1-9/16									
801R	8.0	8.30	SF	D1	5/16	3/8	2	1/4	16.1
1001R	10.0	10.30	SF	D2	5/16	3/8	2	1/4	20.4
1201R	12.0	12.30	SF	D3	5/16	3/8	2	1/4	24.5
1301R	13.0	13.30	SF	D3	5/16	3/8	2	1/4	26.9
1401R	14.0	14.30	SF	D3	5/16	3/8	2	1/4	28.9
1601R	16.0	16.30	SF	D3	5/16	3/8	2	1/4	34.8

SINGLE "S" GROOVE FOR 3230HV BELT F = 2-3/8 GROOVE TOP WIDTH = 2									
801S	8.0	8.4	SF	D1	1/16	5/8	2	7/16	17.3
901S	9.0	9.4	SF	D1	1/16	5/8	2	7/16	21.8
951S	9.5	9.9	SF	D2	1/16	5/8	2	7/16	19.4
1001S	10.0	10.4	SF	D2	1/16	5/8	2	7/16	21.6
1101S	11.0	11.4	SF	D3	1/16	5/8	2	7/16	22.8
1201S	12.0	12.4	SF	D3	1/16	5/8	2	7/16	25.5
1301S	13.0	13.4	SF	D3	1/16	5/8	2	7/16	28.1
1401S	14.0	14.4	SF	D3	1/16	5/8	2	7/16	32.5
1501S	15.0	15.4	SF	D3	1/16	5/8	2	7/16	35.1
1601S	16.0	16.4	SF	D3	1/16	5/8	2	7/16	40.4
1801S	18.0	18.4	SF	D3	1/16	5/8	2	7/16	44.2
2001S	20.0	20.4	SF	D3	1/16	5/8	2	7/16	51.2

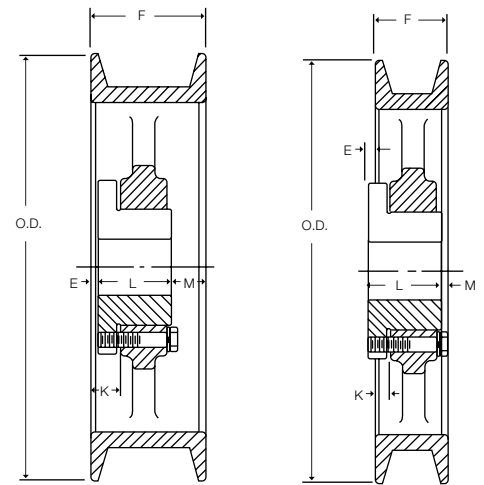

Type A

Type D

Weights for all Sure-Grip items are approximate and include the bushing.

All dimensions in inches.

Figures following letter in column headed "Type" in tables on these pages indicate sheave constructions.
1 - Solid, No Web / 2 - Web / 3 - Arms

SURE GRIP BUSHINGS

Bush- ing	Fig. Dia.	Length	Stock Bore Range		Wt. (lbs.)
			Inches	MM	
SH	2-11/16	1-1/4	1/2 - 1-11/16	24-35	.9
SDS	3-3/16	1-5/16	1/2 - 2	24-42	1.3
SD	3-3/16	1-13/16	1/2 - 2	24-42	1.6
SK	3-7/8	1-7/8	1/2 - 2-5/8	24-55	2.8
SF	4-5/8	2	1/2 - 2-15/16	28-65	3.9
E	6	2-5/8	7/8 - 3-1/2	35-80	8.5
F	6-5/8	3-5/8	1 - 4	45-90	13.9

For more detailed information see A1 section of catalog WGC.

Wide Range Companion Sheaves

Dimensions

The companion sheaves for the motion control variable speed-driver sheaves are made to accommodate Sure-Grip Bushings for ease of installation. The tables below list the dimensions for each.

Product No.	Pitch Dia.	O.D.	Bushing	Type	E	K	L	M	Weight
SINGLE "T" GROOVE FOR 2926V BELT F = 2-1/8					GROOVE TOP WIDTH = 1-13/16				
761T	7.6	7.90	SK	D1	9/32	7/16	1-7/8	15/32	13.6
861T	8.6	8.90	SK	D2	9/32	7/16	1-7/8	15/32	12.8
961T	9.6	9.90	SK	D2	9/32	7/16	1-7/8	15/32	14.8
1061T	10.6	10.90	SK	D2	9/32	7/16	1-7/8	15/32	18.2
1161T	11.6	11.90	SK	D2	9/32	7/16	1-7/8	15/32	20.0
1361T	13.6	13.90	SK	D3	9/32	7/16	1-7/8	15/32	21.2
1561T	15.6	15.90	SK	D3	9/32	7/16	1-7/8	15/32	24.2
1761T	17.6	17.90	SK	D3	9/32	7/16	1-7/8	15/32	30.0
1961T	19.6	19.90	SK	D3	9/32	7/16	1-7/8	15/32	34.1
SINGLE "W" GROOVE FOR 4430V BELT F = 3-1/8					GROOVE TOP WIDTH = 2-3/4				
801W	8.0	8.4	SF	A1	1/8	13/16	2	1	18.6
851W	8.5	8.9	SF	A1	1/8	13/16	2	1	20.9
901W	9.0	9.4	SF	A1	1/8	13/16	2	1	23.3
951W	9.5	9.9	SF	A2	1/8	13/16	2	1	21.2
1001W	10.0	10.4	SF	A2	1/8	13/16	2	1	24.0
1101W	11.0	11.4	SF	A2	1/8	13/16	2	1	25.7
1201W	12.0	12.4	SF	A3	1/8	13/16	2	1	28.3
1301W	13.0	13.4	SF	A3	1/8	13/16	2	1	31.1
1401W	14.0	14.4	SF	A3	1/8	13/16	2	1	33.6
1501W	15.0	15.4	SF	A3	1/8	13/16	2	1	38.4
1601W	16.0	16.4	SF	A3	1/8	13/16	2	1	41.0
1801W	18.0	18.4	SF	A3	1/8	13/16	2	1	46.6
2001W	20.0	20.4	SF	A3	1/8	13/16	2	1	57.0
2201W	22.0	22.4	SF	A3	1/8	13/16	2	1	63.8
2401W	24.0	24.4	SF	A3	1/8	13/16	2	1	73.7
2801W	28.0	28.4	E	A3	1/32	15/16	2-5/8	19/32	106.0
SINGLE "Y" GROOVE FOR 4836V BELT F = 3-3/8					GROOVE TOP WIDTH = 3				
1001Y	10.0	10.45	F	D1	9/16	7/16	3-5/8	5/16	44.8
1101Y	11.0	11.45	F	D1	9/16	7/16	3-5/8	5/16	54.7
1201Y	12.0	12.45	F	D1	9/16	7/16	3-5/8	5/16	66.4
1401Y	14.0	14.45	F	D2	9/16	7/16	3-5/8	5/16	56.7
1601Y	16.0	16.45	F	D3	9/16	7/16	3-5/8	5/16	65.8
1801Y	18.0	18.45	F	D3	9/16	7/16	3-5/8	5/16	72.8
2001Y	20.0	20.45	F	D3	9/16	7/16	3-5/8	5/16	80.0
2401Y	24.0	24.45	F	D3	9/16	7/16	3-5/8	5/16	101.1
3001Y	30.0	30.45	F	D3	9/16	7/16	3-5/8	5/16	135.6

Wide Range Companion Pulleys

Dimensions

The companion pulleys for the motion control variable speed-driver sheaves are made to accommodate Sure-Grip Bushings for ease of installation. The tables below list the dimensions for each.

COMPANION PULLEYS

PRODUCT NO.	BUSH	TYPE	E	L	M	WT.
-------------	------	------	---	---	---	-----

2" STRAIGHT FACE COMPANION PULLEYS

62S	SH	A3	1/16	1-1/4	11/16	4
72S	SH	A3	1/16	1-1/4	11/16	5
82S	SH	A3	1/16	1-1/4	11/16	6
92S	SH	A3	1/16	1-1/4	11/16	6
102S	SH	A3	1/16	1-1/4	11/16	7
112S	SH	A3	1/16	1-1/4	11/16	9
122S	SH	A3	1/16	1-1/4	11/16	11
142S	SDS	A3	0	1-5/16	11/16	14
162S	SDS	A3	0	1-5/16	11/16	16

2-3/4" STRAIGHT FACE COMPANION PULLEYS

4234S	SD	A1	1/2	1-13/16	7/16	4
5234S	SD	A2	1/2	1-13/16	7/16	5
6234S	SD	A3	1/2	1-13/16	7/16	6
7234S	SD	A3	1/2	1-13/16	7/16	7
8234S	SD	A3	1/2	1-13/16	7/16	9
9234S	SD	A3	1/2	1-13/16	7/16	9
10234S	SD	A3	1/2	1-13/16	7/16	12
11234S	SD	A3	1/2	1-13/16	7/16	12
12234S	SD	A3	1/2	1-13/16	7/16	16
14234S	SF	A3	7/16	2	5/16	20
16234S	SF	A3	7/16	2	5/16	22
18234S	SF	A3	0	2	3/4	27
20234S	SF	A3	0	2	3/4	30

4-1/4" STRAIGHT FACE COMPANION PULLEYS

4414S	SD	A1	1/2	1-13/16	1-15/16	5
5414S	SD	A2	1/2	1-13/16	1-15/16	6
6414S	SD	A3	5/8	1-13/16	1-13/16	8
7414S	SD	A3	5/8	1-13/16	1-13/16	8
8414S	SD	A3	5/8	1-13/16	1-13/16	11
9414S	SD	A3	13/16	1-13/16	1-5/8	14
10414S	SD	A3	13/16	1-13/16	1-5/8	14
11414S	SD	A3	13/16	1-13/16	1-5/8	16
12414S	SF	A3	1-3/16	2	1-1/16	21
14414S	SF	A3	1-3/16	2	1-1/16	25
16414S	SF	A3	1-3/16	2	1-1/16	28
18414S	SF	A3	3/4	2	1-1/2	34
20414S	SF	A3	3/4	2	1-1/2	35
24414S	SF	A3	3/4	2	1-1/2	50

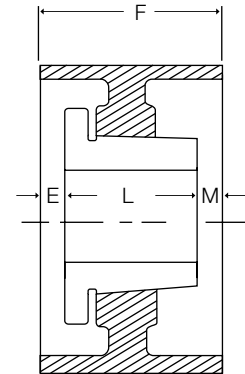

Part no. explanation:

Example: 62S

6 = Outside Diameter

2 = Face Width

STR = Designates straight face
(Necessary to be used as companion.)

V-Belt Adjustable Pitch Sheaves

D2

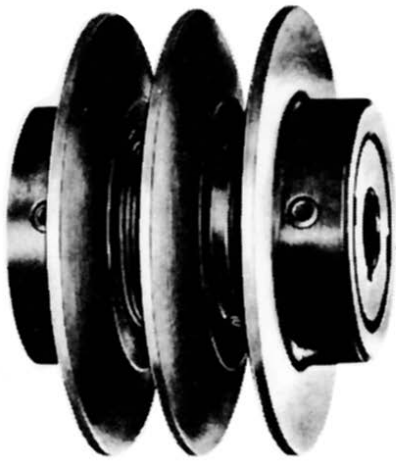

FHP



JVS



5VS-8VS



SVS

Light-Duty (FHP) Adjustable Sheave

Dimensions

The one and two groove adjustable sheaves are machined from annealed cast iron and are designed for 3L, 4L (A), 5L (B) or 5V V-belts. The datum diameter of the sheaves is adjusted by loosening the setscrews in the hubs and turning the threaded flange to the desired setting and then the setscrews are retightened. The sheaves will give 30% change in datum diameter.

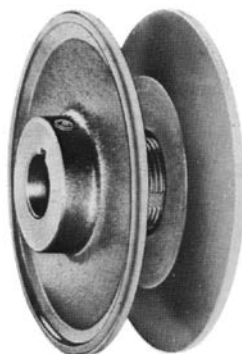

One Groove



Two Groove

VP Series

Pitch Diameter and Turns

One Groove

Product Number	3L or O				4L or A				5L or B				5V			
	Max. Pitch	Turns Open	Min. Pitch	Turns Open	Max. Pitch	Turns Open	Min. Pitch	Turns Open	Max. Pitch	Turns Open	Min. Pitch	Turns Open	Max. Pitch	Turns Open	Min. Pitch	Turns Open
1VP25	2.44	0	1.79	3.5	na	na	na	na	na	na	na	na	na	na	na	na
1VP30	2.69	0	1.87	4	na	na	na	na	na	na	na	na	na	na	na	na
*1VP34	2.90	0	2.08	4	3.04	1.5	2.32	5	3.19	3.5	2.78	5.5	na	na	na	na
1VP40	3.18	0	2.26	4.5	3.62	0	2.39	6	3.77	2	2.95	6	na	na	na	na
1VP44	3.58	0	2.66	4.5	4.02	0	2.79	6	4.17	2	3.35	6	na	na	na	na
1VP50	4.18	0	3.26	4.5	4.62	0	3.39	6	4.77	2	3.95	6	na	na	na	na
1VP56	4.78	0	3.86	4.5	5.22	0	3.49	6	5.37	2	4.55	6	na	na	na	na
1VP60	na	na	na	na	5.85	0	4.12	6	5.91	0	4.68	6	na	na	na	na
1VP62	5.38	0	4.46	4.5	5.82	0	4.59	6	5.97	2	5.15	6	5.87	2	5.07	6
1VP65	na	na	na	na	5.85	0	4.62	6	6.41	0	5.18	6	6.33	0	5.10	6
1VP68	5.98	0	5.06	4.5	6.42	0	5.19	6	6.57	2	5.75	6	6.49	2	5.67	6
1VP71	na	na	na	na	6.45	0	5.22	6	7.01	0	5.78	6	6.93	0	5.70	6
1VP75	na	na	na	na	6.85	0	5.62	6	7.41	0	6.18	6	7.33	0	6.10	6

Two Groove

Product Number	3L or O				4L or A				5L or B				5V			
	Max. Pitch	Turns Open	Min. Pitch	Turns Open	Max. Pitch	Turns Open	Min. Pitch	Turns Open	Max. Pitch	Turns Open	Min. Pitch	Turns Open	Max. Pitch	Turns Open	Min. Pitch	Turns Open
*2VP36	2.78	0	2.27	2.5	3.22	0	2.50	3.5	3.37	2	2.76	5	na	na	na	na
2VP42	3.38	0	2.46	4.5	3.82	0	2.70	5.5	3.97	2	3.15	6	na	na	na	na
2VP50	4.18	0	3.26	4.5	4.62	0	3.37	6	4.77	2	3.95	6	na	na	na	na
2VP56	4.78	0	3.86	4.5	5.22	0	3.99	6	5.37	2	4.55	6	na	na	na	na
2VP60	na	0	na	na	5.35	0	4.12	6	5.91	0	4.68	6	na	na	na	na
2VP62	4.46	0	4.46	4.5	5.82	0	4.59	6	5.97	2	5.15	6	5.89	2	5.07	6
2VP65	na	0	na	na	5.85	0	4.62	6	6.41	0	5.18	6	6.33	0	5.10	6
2VP68	5.06	0	5.06	4.5	6.42	0	5.19	6	6.57	2	5.75	6	6.48	2	5.67	6
2VP71	na	0	na	na	6.45	0	5.22	6	7.01	0	5.78	6	6.93	0	5.70	6
2VP75	na	0	na	na	6.85	0	5.62	6	7.41	0	6.18	6	7.33	0	6.10	6

*Max. Adjustment varies with Bore Size

Light-Duty (FHP) Adjustable Sheave

Dimensions

VP SERIES

One Groove

Product Number	Outside Diameter	Overall Length	Weight Lbs.	Stock Bores									Max Bore	
				1/2	5/8	3/4	7/8	1	1-1/8	1-1/4	1-3/8	1-5/8		
1VP25	2.58	1.59	0.7	x	x	x								3/4
1VP30	2.87	1.66	1.1	x	x	x								3/4
1VP34	3.15	1.88	1.4	x	x	x	x	x	x					1-1/8
1VP40	3.75	1.88	1.9	x	x	x	x	x	x					1-1/8
1VP44	4.15	1.88	2.4	x	x	x	x	x	x					1-1/8
1VP50	4.75	2.00	3.6	x	x	x	x	x	x					1-1/8
1VP56	5.35	1.88	4.4	x	x	x	x	x	x					1-1/8
1VP60	6.00	1.66	6.5		x	x	x		x		x	x		1-5/8
1VP62	5.95	1.91	6.1		x	x	x	x	x	x	x			1-5/8
1VP65	6.50	1.66	6.8			x	x		x		x	x		1-5/8
1VP68	6.55	1.91	7.3		x	x	x	x	x	x	x			1-5/8
1VP71	7.10	1.66	8.5			x	x		x		x	x		1-5/8
1VP75	7.50	1.66	9.2			x	x	x	x		x	x		1-5/8

Two Groove

Product Number	Outside Diameter	Overall Length	Weight Lbs.	Stock Bores									Max Bore	
				1/2	5/8	3/4	7/8	1	1-1/8	1-1/4	1-3/8	1-5/8		
2VP36	3.35	3	3.4	x	x	x	x	x	x					1 1/8
2VP42	3.95	3	4.4		x	x	x	x	x					1-1/8
2VP50	4.75	3	6.3		x	x	x	x	x					1-1/8
2VP56	5.35	3	7.8		x	x	x	x	x		x	x		1-5/8
2VP60	6.00	3.25	10.6			x	x	x	x		x	x		1-5/8
2VP62	5.95	3	10			x	x	x	x	x	x			1-5/8
2VP65	6.50	3.25	12.3			x	x		x		x	x		1-5/8
2VP68	6.55	3	11.7			x	x	x	x	x	x	x		1-5/8
2VP71	7.10	3.25	14.6			x	x		x		x	x		1-5/8
2VP75	7.50	3.25	16.5			x	x	x	x		x	x		1-5/8

Product No. Example: 1VP40 Sheave with 5/8" Bore = 1VP4058 (Product No.)

Bore	Keyseat
1/2	NONE
5/8 to 7/8	3/16 x 3/32
1 to 1-1/4	1/4 x 1/8
1-5/16 x 1-3/8	5/16 x 5/32
1-7/16 x 1-5/8	3/8 x 3/16

JVS Adjustable Speed Sheaves

Features

- For A-B or 5V Belts
- Up to 40 HP @ 1750 rpm
- Needs No Lubrication
- Won't Freeze or Stick
- Wider Speed Range

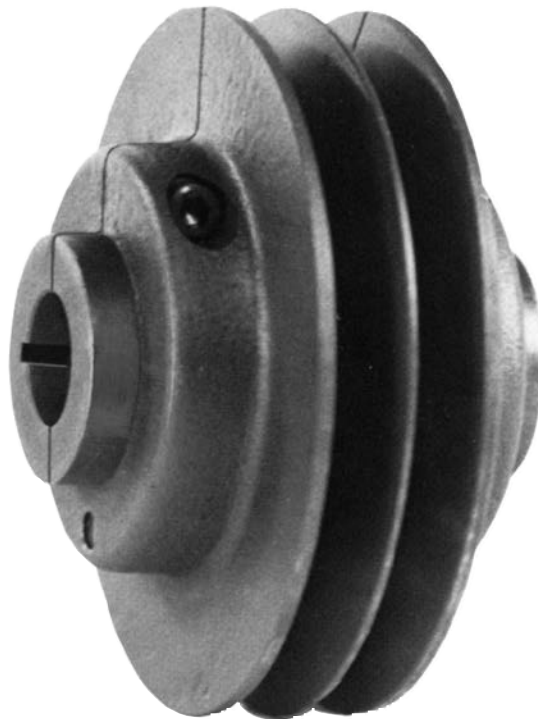

Wood's JVS stationary control, adjustable speed sheaves offer several significant advantages. This sheave is available in 6 sizes from 5.118 inches (130 mm) to 9.055 inches (230 mm) in diameter. It uses Classical A and B belts and Narrow 5V belts. Capacities range up to 40 hp at 1750 rpm. Its speed is infinitely variable, and because one screw controls both moveable flanges, accurate groove spacing is assured at all times. It uses a clamping collar design with no threads on either the sleeve or the flanges, so there is no chance of fretting corrosion and sticking. No lubrication is needed.

JVS Adjustable Speed Sheaves

Dimensions

Product No.	Stock Bores	Max. Bore
JVS1302	1-1/8, 1-3/8	1.3750
JVS1502	1-1/8, 1-3/8, 1-5/8	1.6875
JVS1702	1-1/8, 1-3/8, 1-5/8	1.6875
JVS1902	1-3/8, 1-5/8, 1-7/8	2.4375
JVS2102	1-3/8, 1-5/8, 1-7/8, 2-1/8	2.4375
JVS2302	1-3/8, 1-5/8, 1-7/8, 2-1/8	2.4375

Product No. Example:

JVS1302 with 1-3/8" Bore = JVS1302138 (Product No.)

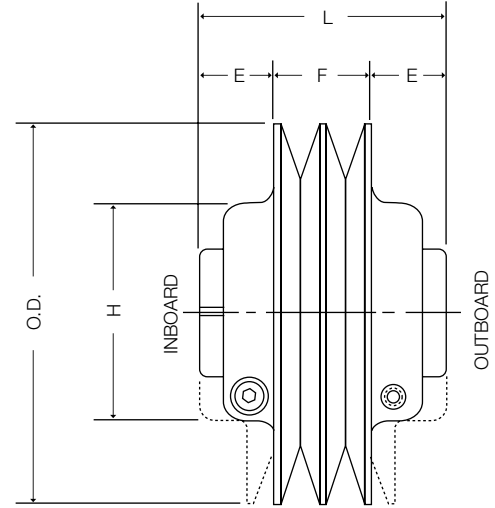

Product No.	PITCH DIA. RANGE			O.D.	DIMENSIONS						WT. (Lbs.)
	A Belts	B Belts	5V Belts		L	F		E		H	
						Min.	Max.	Min.	Max.		
JVS1302	3.86 - 4.58	4.22 - 5.14	-	5.12	3.77	1.73	2.27	.75	1.02	3.19	8.0
JVS1502	4.44 - 5.36	4.49 - 5.92	4.41 - 5.84 †	5.90	4.13	1.73	2.59	.77	1.20	3.62	11.0
JVS1702	5.13 - 6.15	5.5 - 5.28	5.2 - 6.63 †	6.69	4.13	1.73	2.59	.77	1.20	3.62	13.5
JVS1902	5.92 - 6.94	5.5 - 6.07	5.99 - 7.42	7.48	4.13	1.73	2.59	.77	1.20	5.09	20.0
JVS2102	6.71 - 7.73	5.5 - 6.87	6.78 - 8.21	8.27	4.13	1.73	2.59	.77	1.20	5.09	23.0
JVS2302	7.15 - 8.52	5.5 - 7.65	7.57 - 9.00	9.06	4.13	1.73	2.59	.77	1.20	5.09	26.0

Note: JVS sheaves use standard 2 Groove "B" or "5V" sheaves as companions.

† Recommended for use with Narrow Cog Belts only.

Note: One turn of the adjusting screw varies the pitch .2". Maximum to minimum adjustment requires seven turns.

5VS And 8VS Ultra-V Adjustable Sheave

Features

- For the 5V & 8V Narrow Belt
- More hp per inch Face Width
- Capacities to 500 hp @ 1750 rpm
- Interchangeable Bushings
- Needs No Lubrication
- Won't Freeze or Stick



The narrow stationary control adjustable speed sheaves feature a design which uses a tapered bushing to lock all moveable parts and clamp the sheave to the shaft, thus eliminating fretting corrosion and minimizing unbalance. The 5VS sheaves are available in five basic sizes—5VS240, 5VS265, 5VS290, 5VS315 and 5VS355. The 5VS240 and 5VS265 sheaves are available with 2 through 6 grooves; and the 5VS290 through 5VS355 with 2 through 8 grooves. The 8VS sheaves are available in two basic sizes—8VS355 and 8VS-405, which are available with 4 through 8 grooves.

These sheaves are fitted with a split interchangeable bushing which is carried in stock with the popular bores. See chart on following pages for bores available from stock.

Companion sheave selection depends upon the number of grooves in the 5VS sheave.

5VS SHEAVE	USE COMPANION
2 Groove	2 Groove – Stock 5V
3 Groove	5 Groove – Stock 5V
4 Groove	7 Groove – Stock 5V
5 Groove	9 Groove – Stock 5V
6 Groove	Stock 6 Groove Wide Space Companion
8 Groove	MTO 8 Groove Wide Spaced Companion

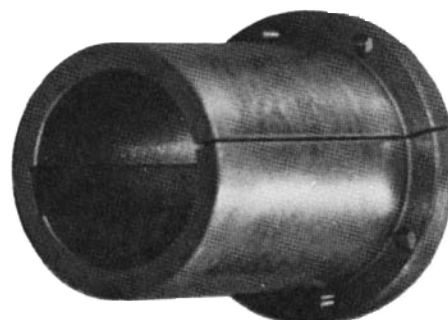

NOTE: 8VS Sheaves use MTO 8V Wide Groove Companions

5VS Adjustable Sheaves

Dimensions

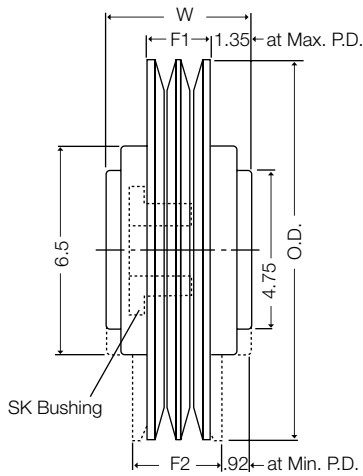

2 Groove Only
Max. to min. pitch 7-1/2 turns.
Each turn varies pitch .18".

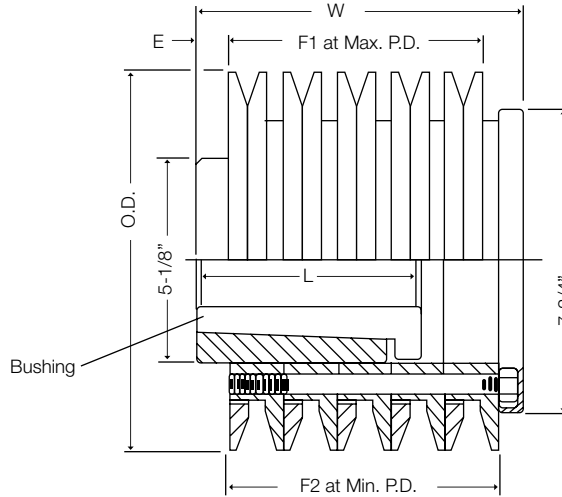

3 Thru 8 Grooves
Max. to min. pitch 5.5 turns.
Each turn varies pitch .25".

5VS SHEAVES

2, 3, 4, 5, 6 & 8
GROOVES

Product No.	P.D.		O.D.	Bushing Product No	DIMENSIONS					WT. Lbs.
	Min.	Max.			F1	F2	W	E	L	
5VS2402	8.20	9.57	9.56	SK	1.89	2.75	4.59	-	-	34
5VS2403	8.20	9.57	9.56	5VSSB	3.70	4.13	5.30	.43	5.27	52
5VS2404	8.20	9.57	9.56	5VSSB	5.07	5.50	6.67	.43	5.27	64
5VS2405	8.20	9.57	9.56	5VSSB	6.45	6.88	8.05	.43	5.27	76
5VS2406	8.20	9.57	9.56	5VSLB	7.80	8.26	9.43	.43	8.46	100
5VS2652	9.19	10.57	10.56	SK	1.89	2.75	4.59	-	-	40
5VS2653	9.19	10.57	10.56	5VSSB	3.70	4.13	5.30	.43	5.27	62
5VS2654	9.19	10.57	10.56	5VSSB	5.07	5.50	6.67	.43	5.27	78
5VS2655	9.19	10.57	10.56	5VSSB	6.45	6.88	8.05	.43	5.27	92
5VS2656	9.19	10.57	10.56	5VSLB	7.80	8.26	9.43	.43	8.46	118
5VS2902	10.17	11.55	11.54	SK	1.89	2.75	4.59	-	-	46
5VS2903	10.17	11.55	11.54	5VSSB	3.70	4.13	5.30	.43	5.27	74
5VS2904	10.17	11.55	11.54	5VSSB	5.07	5.50	6.67	.43	5.27	92
5VS2905	10.17	11.55	11.54	5VSSB	6.45	6.88	8.05	.43	5.27	110
5VS2906	10.17	11.55	11.54	5VSLB	7.80	8.26	9.43	.43	8.46	140
5VS2908	10.17	11.55	11.54	5VSLB	10.56	11.00	12.18	.43	8.46	178
5VS3152	11.15	12.53	12.52	SK	1.89	2.75	4.59	-	-	52
5VS3153	11.15	12.53	12.52	5VSSB	3.70	4.13	5.30	.43	5.27	84
5VS3154	11.15	12.53	12.52	5VSSB	5.07	5.50	6.67	.43	5.27	106
5VS3155	11.15	12.53	12.52	5VSSB	6.45	6.88	8.05	.43	5.27	130
5VS3156	11.15	12.53	12.52	5VSLB	7.80	8.26	9.43	.43	8.46	162
5VS3158	11.15	12.53	12.52	5VSLB	10.56	11.00	12.18	.43	8.46	210
5VS3552	12.72	14.10	14.09	SK	1.89	2.75	4.59	-	-	52
5VS3553	12.72	14.10	14.09	5VSSB	3.70	4.13	5.30	.43	5.27	104
5VS3554	12.72	14.10	14.09	5VSSB	5.07	5.50	6.67	.43	5.27	133
5VS3555	12.72	14.10	14.09	5VSSB	6.45	6.88	8.05	.43	5.27	164
5VS3556	12.72	14.10	14.09	5VSLB	7.80	8.26	9.43	.43	8.46	202
5VS3558	12.72	14.10	14.09	5VSLB	10.56	11.00	12.18	.43	8.46	264

Note: All dimensions in the above tables are in inches.
Maximum speed of all 5VS sheaves is 1800 RPM.

BUSHING DIMENSIONS

Prod. No.	Stock Bores	Diameter	Length	Wt. (Lbs.)
5VSSB	1-7/8, 2-1/8, 2-3/8, 2-7/8, 3-3/8	5.10	5.27	11.5
5VSLB	2-3/8, 2-7/8, 3-3/8*	5.10	8.46*	9.0

* 3-3/8 Bore only; Length = 7.0

Product No. Example: 5VSSB Bushing with a 2-3/8" Bore = 5VSSB238 (Product No.)

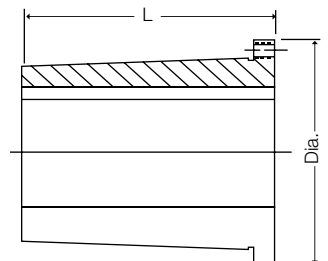

Companion Sheaves For 5VS Adjustables

Dimensions

O.D. ◆	6 GROOVES (WIDE GROOVE SPACING)								8 GROOVES (WIDE GROOVE SPACING)*					
	Product No.	F = 7.88							F = 10.62					
		Bush.	Type	E	K	L	M	Wt.	Bush.	Type	E	K	L	M
8.0	-	-	-	-	-	-	-	-	E	A	3.38	4.25	2.62	4.62
8.5	-	-	-	-	-	-	-	-	E	A	3.38	4.25	2.62	4.62
9.0	-	-	-	-	-	-	-	-	F	A	2.38	3.38	3.62	4.62
9.25	-	-	-	-	-	-	-	-	F	A	2.38	3.38	3.62	4.62
9.75	-	-	-	-	-	-	-	-	F	A	2.38	3.38	3.62	4.62
10.3	5V1036W	F	A1	2-1/8	3-1/8	3-5/8	2-1/8	81.4	F	A	2.38	3.38	3.62	4.62
10.9	5V1096W	F	A1	2-1/8	3-1/8	3-5/8	2-1/8	89.2	J	A	2.5	3.68	4.5	3.62
11.3	5V1136W	F	A1	2-1/8	3-1/8	3-5/8	2-1/8	97.7	J	A	2.5	3.68	4.5	3.62
11.8	5V1186W	F	A1	2-1/8	3-1/8	3-5/8	2-1/8	103.9	J	A	2.5	3.68	4.5	3.62
12.5	5V1256W	F	A2	2-1/8	3-1/8	3-5/8	2-1/8	95.7	J	A	2.5	3.68	4.5	3.62
13.2	5V1326W	F	A2	2-1/8	3-1/8	3-5/8	2-1/8	102.3	J	A	2.5	3.68	4.5	3.62
14.0	5V1406W	F	A2	2-1/8	3-1/8	3-5/8	2-1/8	111.6	J	A	2.5	3.68	4.5	3.62
15.0	5V1506W	F	A3	2-1/8	3-1/8	3-5/8	2-1/8	110.9	M	A	2.5	3.68	4.5	3.62
16.0	5V1606W	F	A3	2-1/8	3-1/8	3-5/8	2-1/8	119.4	M	A	1.25	2.68	6.75	2.62
18.7	5V1876W	J	A3	3/4	1-15/16	4-1/2	2-5/8	160.8	M	A	1.25	2.68	6.75	2.62
20.0	-	-	-	-	-	-	-	-	M	A	1.25	2.68	6.75	2.62
21.2	5V2126W	J	A3	3/4	1-15/16	4-1/2	2-5/8	186.3	M	A	1.25	2.68	6.75	2.62
23.6	5V2366W	J	A3	3/4	1-15/16	4-1/2	2-5/8	218.3	M	A	1.25	2.68	6.75	2.62
25.0	-	-	-	-	-	-	-	-	M	A	1.25	2.68	6.75	2.62
28.0	5V2806W	J	A3	3/4	1-15/16	4-1/2	2-5/8	235.8	M	A	1.25	2.68	6.75	2.62
30.0	-	-	-	-	-	-	-	-	M	A	1.25	2.68	6.75	2.62
31.5	5V3156W	J	A3	3/4	1-15/16	4-1/2	2-5/8	272.4	M	A	1.25	2.68	6.75	2.62
35.5	-	-	-	-	-	-	-	..	N	A	0	1.75	8.12	2.5
37.5	5V3756W	J	A3	3/4	1-15/16	4-1/2	2-5/8	357.9	N	A	0	1.75	8.12	2.5
42.5	-	-	-	-	-	-	-	-	N	A	0	1.75	8.12	2.5
46.0	-	-	-	-	-	-	-	-	N	A	0	1.75	8.12	2.5
50.0	5V5006W	M	A3	15/32	1-15/16	6-3/4	21/32	648.0	N	A	0	1.75	8.12	2.5
53.0	-	-	-	-	-	-	-	-	N	A	0	1.75	8.12	2.5
58.0	-	-	-	-	-	-	-	-	N	A	0	1.75	8.12	2.5
64.0	-	-	-	-	-	-	-	-	P	A	0	2.0	9.38	1.24
72.0	-	-	-	-	-	-	-	-	P	A	0	2.0	9.38	1.24

◆ P.D. = O.D.

* 8 Groove companions are MTO.

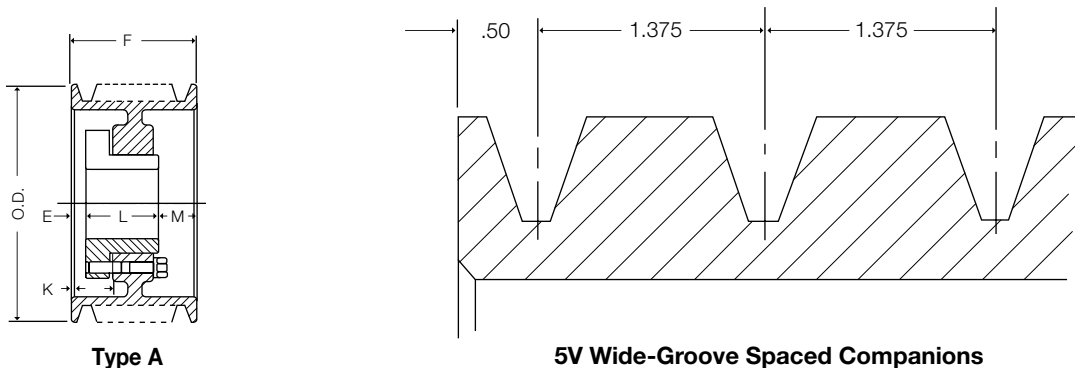

8VS Adjustable Speed Sheaves

Dimensions

8VS SHEAVES 4, 5, 6 & 8 GROOVE

Max. to min. adjustment requires 8 turns. Pitch varies .24" per turn.

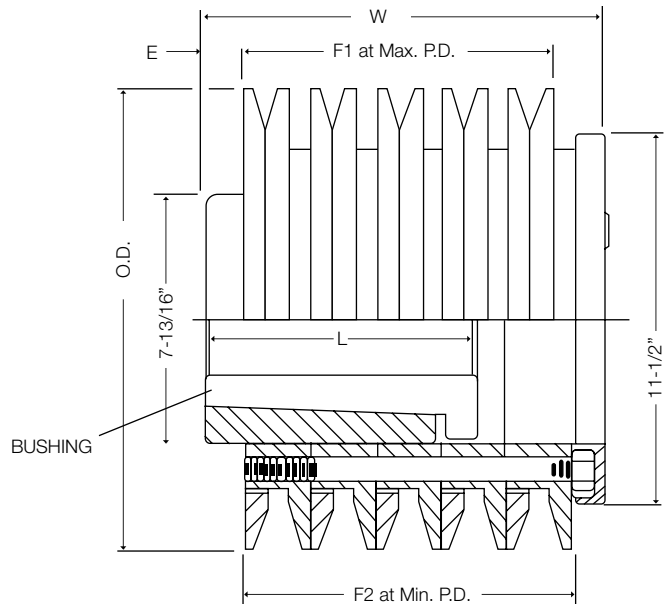

Product No.	P.D.		O.D.	Bushing	DIMENSIONS					WT.* Lbs.
	Min.	Max.			F1	F2	W	E	L	
8VS3554	12.48	14.37	14.17	8VS-SB	7.22	7.87	9.70	.65	9.33	187
8VS3555	12.48	14.37	14.17	8VS-SB	9.18	9.84	11.67	.65	9.33	220
8VS3556	12.48	14.37	14.17	8VS-SB	11.15	11.81	13.64	.65	9.33	256
8VS3558	12.48	14.37	14.17	8VS-LB	15.09	15.75	17.58	.65	12.36	340
8VS4054	14.45	16.34	16.14	8VS-SB	7.22	7.87	9.70	.65	9.33	215
8VS4055	14.45	16.34	16.14	8VS-SB	9.18	9.84	11.67	.65	9.33	250
8VS4056	14.45	16.34	16.14	8VS-SB	11.15	11.81	13.64	.65	9.33	290
8VS4058	14.45	16.34	16.14	8VS-LB	15.09	15.75	17.58	.65	12.36	388

* Weight does not include bushing.

Note: Max. RPM of 8VS-355 is 1800 and for 8VS-405 the max. RPM is 1500.

BUSHING DIMENSIONS

Prod. No.	Stock Bores	Diameter	Length	Wt. (Lbs.)
8VSSB	3-3/8, 3-7/8	7.75	9.33	34.0
8VSLB	3-3/8, 3-7/8, 4-3/8	7.75	12.36	40.0

Product No. Example: 8VSLB Bushing with 3-7/8" Bore = 8VSLB378 (Product No.)

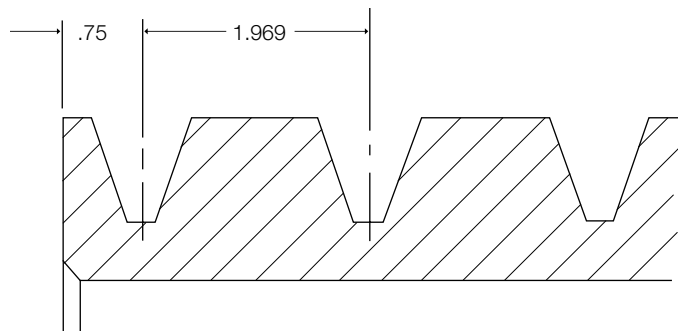
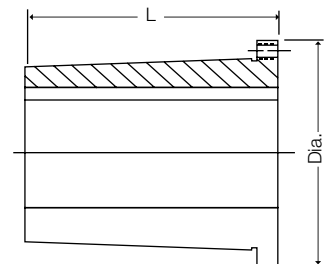

Companion Sheaves For 8VS Adjustables

Dimensions

The companion sheaves for 8VS Adjustables have wide groove spacing and are made-to-order. The diameters can vary from those shown. However, the drives in the pre-engineered drive tables use the diameters listed here.

O.D. ◆	4 GROOVES (wide groove spacing)						5 GROOVES (wide groove spacing)						6 GROOVES (wide groove spacing)						8 GROOVES (wide groove spacing)					
	F = 7.41						F = 9.38						F = 11.34						F = 15.28					
	Bush.	Type	E	K	L	M	Bush.	Type	E	K	L	M	Bush.	Type	E	K	L	M	Bush.	Type	E	K	L	M
12.5	F	A	1.38	2.38	3.62	2.40	F	A	2.38	3.38	3.62	3.37	J	A	2.38	3.56	4.5	4.46	J	A	4.25	5.44	4.5	6.53
13.2	F	A	1.38	2.38	3.62	2.40	F	A	2.38	3.38	3.62	3.37	J	A	2.38	3.56	4.5	4.46	J	A	4.25	5.44	4.5	6.53
14.0	F	A	1.38	2.38	3.62	2.40	F	A	2.38	3.38	3.62	3.37	J	A	2.38	3.56	4.5	4.46	J	A	4.25	5.44	4.5	6.53
15.0	F	A	1.38	2.38	3.62	2.40	F	A	2.38	3.38	3.62	3.37	J	A	2.38	3.56	4.5	4.46	J	A	4.25	5.44	4.5	6.53
16.0	F	A	1.38	2.38	3.62	2.40	J	A	1.5	2.68	4.5	3.37	J	A	2.38	3.56	4.5	4.46	J	A	4.25	5.44	4.5	6.53
17.0	J	A	1.38	2.38	3.62	2.40	J	A	1.5	2.68	4.5	3.37	J	A	2.38	3.56	4.5	4.46	M	A	2.75	4.18	6.75	5.78
18.0	J	A	.94	2.12	4.5	1.96	J	A	1.5	2.68	4.5	3.37	J	A	2.38	3.56	4.5	4.46	M	A	2.75	4.18	6.75	5.78
19.0	J	A	.94	2.12	4.5	1.96	J	A	1.5	2.68	4.5	3.37	J	A	2.38	3.56	4.5	4.46	M	A	2.75	4.18	6.75	5.78
20.0	J	A	.94	2.12	4.5	1.96	J	A	1.5	2.68	4.5	3.37	M	A	.75	2.18	6.75	3.84	M	A	2.75	4.18	6.75	5.78
21.2	J	A	.94	2.12	4.5	1.96	J	A	1.5	2.68	4.5	3.37	M	A	.75	2.18	6.75	3.84	M	A	2.75	4.18	6.75	5.78
22.4	J	A	.94	2.12	4.5	1.96	M	A	.25	1.68	6.75	2.37	M	A	.75	2.18	6.75	3.84	M	A	2.75	4.18	6.75	5.78
23.6	J	A	.94	2.12	4.5	1.96	M	A	.25	1.68	6.75	2.37	M	A	.75	2.18	6.75	3.84	M	A	2.75	4.18	6.75	5.78
24.8	M	A	0	1.44	6.75	.65	M	A	.25	1.68	6.75	2.37	M	A	.75	2.18	6.75	3.84	M	A	2.75	4.18	6.75	5.78
28.0	M	A	0	1.44	6.75	.65	M	A	.25	1.68	6.75	2.37	M	A	.75	2.18	6.75	3.84	M	A	2.75	4.18	6.75	5.78
30.0	M	A	0	1.44	6.75	.65	M	A	.25	1.68	6.75	2.37	M	A	.75	2.18	6.75	3.84	N	A	2.75	4.5	8.12	4.41
35.5	M	A	0	1.44	6.75	.65	M	A	.25	1.68	6.75	2.37	M	A	.75	2.18	6.75	3.84	N	A	2.75	4.5	8.12	4.41
40.0	M	A	0	1.44	6.75	.65	M	A	.25	1.68	6.75	2.37	N	A	.75	2.5	8.12	2.47	N	A	2.75	4.5	8.12	4.41
42.5	M	A	0	1.44	6.75	.65	N	A	0	1.75	8.12	1.25	N	A	.75	2.5	8.12	2.47	N	A	2.75	4.5	8.12	4.41
44.5	M	A	0	1.44	6.75	.65	N	A	0	1.75	8.12	1.25	N	A	.75	2.5	8.12	2.47	P	A	2.75	4.5	8.12	4.41
48.0	M	A	0	1.44	6.75	.65	N	A	0	1.75	8.12	1.25	N	A	.75	2.5	8.12	2.47	P	A	2.0	4.0	9.38	3.90
53.0	N	B	.25	1.5	8.12	.47	N	A	0	1.75	8.12	1.25	N	A	.75	2.5	8.12	2.47	P	A	2.0	4.0	9.38	3.90
58.0	N	B	.25	1.5	8.12	.47	N	A	0	1.75	8.12	1.25	N	A	.75	2.5	8.12	2.47	P	A	2.0	4.0	9.38	3.90
63.0	N	B	.25	1.5	8.12	.47	N	A	0	1.75	8.12	1.25	P	A	0	2.0	9.38	1.96	P	A	2.0	4.0	9.38	3.90
71.0	N	B	.25	1.5	8.12	.47	P	A	0	2.0	9.37	0	P	A	0	2.0	9.38	1.96	P	A	2.0	4.0	9.38	3.90
78.0	N	B	.25	1.5	8.12	.47	P	A	0	2.0	9.37	0	P	A	0	2.0	9.38	1.96	P	A	2.0	4.0	9.38	3.90

◆ P.D. = O.D.
 To order specify "8V" + O.D. + "X" + Number of Grooves + "W"
 Example: 8V22.4 x 6W

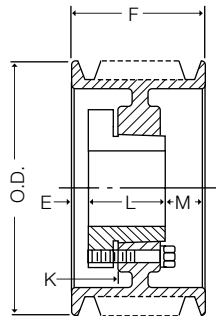

Type A

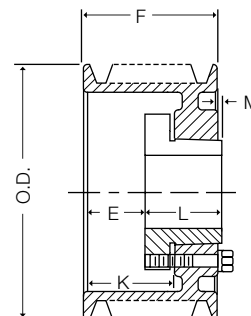

Type B

Features

Wood's SVS standard V-belt adjustable speed sheave is a stationary control, multiple groove unit which provides accurate and infinite speed control within the datum diameter range of each sheave. There is no sticking or freezing. No lubrication is required. This sheave is easily installed, simply adjusted and accurately balanced to assure smooth operation and long drive life. It is of simple, highly efficient design and sturdy construction.



Type 1

U.S. Patent 2,753,723-2,907,597

All SVS sheaves are designed to provide easy datum diameter variation through a single adjusting screw. Positive locking collars clamp the adjustable flanges to the sleeve, thereby eliminating relative motion between sheave parts during operation. This prevents the fretting corrosion and freezing that could cause the unit to become non-adjustable.

SVS standard adjustable sheaves provide infinite speed variation within the range of the datum diameter variation. B Sheaves require 10.25 turns of the adjusting screw from max. to min., and C Sheaves require 14 turns. One turn changes the pitch dia. .14 (B) and .16 (C).

Wood's Type 1 for 2, 3 and 4 groove SVS sheaves are designed to operate with standard conventional fixed pitch companion sheaves having the industry standard groove spacing.

B SVS Adjustable Sheaves

Dimensions

Wood's B-section SVS stationary control adjustable speed sheaves are available in 2, 3 and 4 groove sizes. When the center distance exceeds 12 inches for 2 groove drives and 16 inches for 3 and 4 groove drives, sheaves with standard groove spacing can be used as the companion sheave.

The B-SVS sheaves are also designed to accept A V-belts. The table below lists the P.D. Range for both A and B V-belts.

B SVS SHEAVES 2, 3 & 4 GROOVE

Product No.	Pitch Diameter		O.D.	Stock Bores	Max. Bore	Wt.
	A	B				
SVS49B2	3.62-4.75	3.91-5.31	5.25	7/8, 1-1/8, 1-3/8	1-3/8	14.3
SVS49B3	3.62-4.75	3.91-5.31	5.25	1-1/8, 1-3/8	1-3/8	17.5
SVS49B4	3.62-4.75	3.91-5.31	5.25	1-1/8, 1-3/8	1-3/8	20.0
SVS54B2	4.15-5.25	4.41-5.81	5.75	7/8, 1-1/8, 1-3/8	1-3/8	15.5
SVS54B3	4.15-5.25	4.41-5.81	5.75	1-1/8, 1-3/8	1-3/8	19.0
SVS54B4	4.15-5.25	4.41-5.81	5.75	1-1/8, 1-3/8	1-3/8	22.5
SVS59B2	4.62-5.75	4.91-6.31	6.25	1-1/8, 1-3/8, 1-5/8	1-7/8	18.8
SVS59B3	4.62-5.75	4.91-6.31	6.25	1-1/8, 1-3/8, 1-5/8	1-7/8	23.5
SVS59B4	4.62-5.75	4.91-6.31	6.25	1-3/8, 1-5/8, 1-7/8	1-7/8	27.0
SVS64B2	5.15-6.25	5.41-6.81	6.75	1-1/8, 1-3/8, 1-5/8	1-7/8	20.8
SVS64B3	5.15-6.25	5.41-6.81	6.75	1-3/8, 1-5/8, 1-7/8	1-7/8	24.8
SVS64B4	5.15-6.25	5.41-6.81	6.75	1-5/8, 1-7/8	1-7/8	27.3
SVS69B2	5.65-6.75	5.91-7.31	7.25	1-1/8, 1-3/8, 1-5/8	1-7/8	22.3
SVS69B3	5.65-6.75	5.91-7.31	7.25	1-3/8, 1-5/8, 1-7/8	1-7/8	27.0
SVS69B4	5.65-6.75	5.91-7.31	7.25	1-5/8, 1-7/8	1-7/8	30.5
SVS74B2	6.15-7.25	6.41-7.81	7.75	1-1/8, 1-3/8, 1-5/8	2-3/8	26.3
SVS74B3	6.15-7.25	6.41-7.81	7.75	1-5/8, 1-7/8	2-3/8	32.0
SVS74B4	6.15-7.25	6.41-7.81	7.75	1-5/8, 1-7/8, 2-1/8	2-3/8	37.3
SVS84B2	7.15-8.25	7.41-8.81	8.75	1-3/8, 1-5/8	2-3/8	29.0
SVS84B3	7.15-8.25	7.41-8.81	8.75	1-3/8, 1-5/8, 1-7/8	2-3/8	32.0
SVS84B4	7.15-8.25	7.41-8.81	8.75	1-5/8, 1-7/8, 2-1/8	2-3/8	43.0
SVS94B2	8.15-9.25	8.41-9.81	9.75	1-3/8, 1-5/8	2-3/8	32.5
SVS94B3	8.15-9.25	8.41-9.81	9.75	1-5/8, 1-7/8	2-3/8	42.0
SVS94B4	8.15-9.25	8.41-9.81	9.75	1-5/8, 1-7/8, 2-1/8	2-3/8	50.3

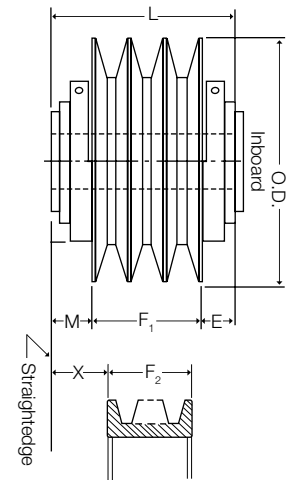

Type 1

Product No. Example: SVS64B3 with 1-3/8" Bore = SVS64B3138 (Product No.)

DIMENSIONS

No. of Grooves	L	F ₁		E		M		F ₂	X	F ₂	X
		Min.	Max.	Min.	Max.	Min.	Max.				
2	4-3/16	1-9/16	2-7/16	7/8	1-5/16	7/8	1-5/16	1-3/4	1-7/32	1-15/16	1-1/8
3	5-5/16	2-1/4	3-9/16	7/8	1-5/16	7/8	1-3/4	2-1/2	1-27/32	2-7/8	1-11/32
4	6-7/16	3	4-11/16	7/8	1-23/32	7/8	1-23/32	3-1/4	1-19/32	3-13/16	1-5/16

These dimensions would apply if Companion Sheaves having wide groove spacing are used.

C SVS Adjustable Sheaves

Dimensions

Wood's C-section stationary control adjustable speed sheaves are available in 2, 3 & 4 groove sizes. When the center distance exceeds 19 inches for 2 groove drives and 25 inches for 3 and 4 groove drives, sheaves with standard groove spacing can be used as the companion sheave.

C SVS SHEAVES 2, 3 & 4 GROOVE

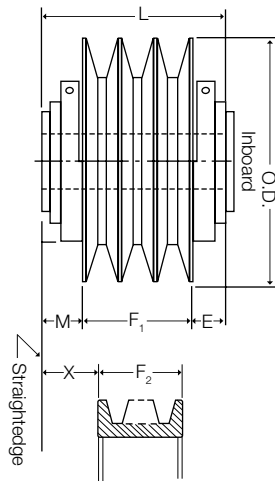

Type 1

Product No.	Pitch Diameter	O.D.	Stock Bores	Max. Bore	Wt.
SVS92C2	7.50-9.70	9.56	1-5/8, 1-7/8	2-1/2	40.5
SVS92C3	7.50-9.70	9.56	1-5/8, 1-7/8, 2-1/8	2-1/2	54.0
SVS92C4	7.50-9.70	9.56	2-1/8, 2-3/8	2-1/2	63.0
SVS102C2	8.50-10.70	10.56	1-5/8, 1-7/8, 2-1/8	2-1/2	44.3
SVS102C3	8.50-10.70	10.56	1-7/8, 2-1/8, 2-3/8	2-1/2	59.0
SVS102C4	8.50-10.70	10.56	2-1/8, 2-3/8	2-1/2	71.8
SVS107C2	9.00-11.20	11.06	1-5/8, 1-7/8, 2-1/8	2-1/2	49.3
SVS107C3	9.00-11.20	11.06	1-7/8, 2-1/8, 2-3/8	2-1/2	62.8
SVS107C4	9.00-11.20	11.06	2-1/8, 2-3/8	2-1/2	76.0
SVS112C2	9.50-11.70	11.56	1-5/8, 1-7/8, 2-1/8	2-1/2	50.5
SVS112C3	9.50-11.70	11.56	1-7/8, 2-1/8, 2-3/8	2-1/2	68.3
SVS112C4	9.50-11.70	11.56	2-1/8, 2-3/8	2-1/2	82.5
SVS117C2	10.00-12.20	12.06	1-5/8, 1-7/8, 2-1/8	2-1/2	55.0
SVS117C3	10.00-12.20	12.06	1-7/8, 2-1/8, 2-3/8	2-1/2	69.5
SVS117C4	10.00-12.20	12.06	2-1/8, 2-3/8	2-1/2	85.5
SVS127C2	11.00-13.20	13.06	1-5/8, 1-7/8, 2-1/8	2-1/2	59.8
SVS127C3	11.00-13.20	13.06	1-7/8, 2-1/8, 2-3/8	2-1/2	76.0
SVS127C4	11.00-13.20	13.06	2-1/8, 2-3/8	2-1/2	91.0

Product No. Example: SVS92C2 with 1-5/8" Bore = SVS92C2158 (Product No.)

DIMENSIONS

No. of Grooves	L	F ₁		E		M		F ₁	X	F ₂	X
		Min.	Max.	Min.	Max.	Min.	Max.				
2	5-1/4	2-1/16	3-1/4	1	1-19/32	1	1-19/32	2-3/8	1-7/16	2-3/8	1-5/16
3	6-7/8	3	4-3/4	1	1-9/16	1-1/8	2-5/16	3-3/8	2-13/32	3-7/8	1-23/32
4	8-9/16	3-15/16	6-5/16	1-1/8	2-5/16	1-1/8	2-5/16	4-3/8	2-3/32	5-1/8	1-23/32

These dimensions would apply if Companion Sheaves having wide groove spacing are used.

Premier Industrial Company Leading Brands

OTHER PRODUCT SOLUTIONS FROM **ALTRA MOTION**

Our comprehensive product offerings include various types of clutches and brakes, overrunning clutches, engineered bearing assemblies, gearing and gear motors along with linear motion products, belted drives, couplings, limit switches, precision motors, drives & controls, miniature motors and engine braking systems. With thousands of product solutions available, Altra provides true single source convenience while meeting specific customer requirements. Many major OEMs and end users prefer Altra products as their No. 1 choice for performance and reliability.

WWW.ALTRAMOTION.COM



Electric Clutches & Brakes

Inertia Dynamics
Matrix
Stromag
Warner Electric



Precision Motors & Automation

Kollmorgen



Heavy Duty Clutches & Brakes

Industrial Clutch
Stromag
Svendborg Brakes
Twiflex
Wichita Clutch



Miniature Motors

Portescap



Overrunning Clutches

Formsprag Clutch
Marland Clutch
Stieber



Linear Systems

Thomson



Engineered Couplings & Universal Joints

Ameridrives
Bibby Turboflex
Guardian Couplings
Huco
Lamiflex Couplings
Stromag
TB Wood's



Engine Braking Systems

Jacobs Vehicle Systems



Gear Drives & Gear Motors

Bauer Gear Motor
Boston Gear
Delroyd Worm Gear
Nuttall Gear



Specialty Components

Kilian
Stromag
TB Wood's

TB Wood's Facilities

North America

USA

440 North Fifth Avenue
Chambersburg, PA 17201 - USA
888-829-6637 * 717-264-7161
Belted Drives and Elastomeric Couplings

Customer Service

1-888-829-6637 (Press #5)

For Application Support

1-888-829-6637 (Press #7)

2000 Clovis Barker Road
San Marcos, TX 78666 - USA
1-888-449-9439
General Purpose Disc Couplings

Customer Service

1-888-449-9439

4970 Joule St
Reno, NV 89502 - USA
775-857-1800

Canada

9779 45 Ave NW
Edmonton, AB T6E 5V8 - Canada
+1 780-439-7979

6305 Danville Road
Mississauga, ON L5T 2H7 - Canada
1-800-829-6631

1073 Rue Bégin
Saint-Laurent, QC H4R 1V8 - Canada
+1 514-332-4812

Mexico

Comisión Federal de Electricidad 850,
Industrial San Luis,
San Luis, S.L.P., 78395 - Mexico
+52 444 137 1500

Europe

Merchant Drive, Hertford
Hertfordshire SG13 7BL - England
+44(0)1992 501900
Elastomeric Couplings

The Brands of Altra Motion

Couplings

Ameridrives
www.ameridrives.com

Bibby Turboflex
www.bibbyturboflex.com

Guardian Couplings
www.guardiancouplings.com

Huco
www.huco.com

Lamiflex Couplings
www.lamiflexcouplings.com

Stromag
www.stromag.com

TB Wood's
www.tbwoods.com

Linear Systems

Thomson
www.thomsonlinear.com

Geared Cam Limit Switches

Stromag
www.stromag.com

Engineered Bearing Assemblies

Kilian
www.kilianbearings.com

Electric Clutches & Brakes

Matrix
www.matrix-international.com

Stromag
www.stromag.com

Warner Electric
www.warnerelectric.com

Deltran
www.thomsonlinear.com

Belted Drives

TB Wood's
www.tbwoods.com

Heavy Duty Clutches & Brakes

Twiflex
www.twiflex.com

Stromag
www.stromag.com

Svendborg Brakes
www.svendborg-brakes.com

Wichita Clutch
www.wichitaclutch.com

Gearing & Specialty Components

Bauer Gear Motor
www.bauergears.com

Boston Gear
www.bostongear.com

Delevan
www.delevan.com

Delroyd Worm Gear
www.delroyd.com

Nuttall Gear
www.nuttallgear.com

Engine Braking Systems

Jacobs Vehicle Systems
www.jacobsvehiclesystems.com

Precision Motors & Automation

Kollmorgen
www.kollmorgen.com

Miniature Motors

Portescap
www.portescap.com

Overrunning Clutches

Formsprag Clutch
www.formsprag.com

Marland Clutch
www.marland.com

Stieber
www.stieberclutch.com

Neither the accuracy nor completeness of the information contained in this publication is guaranteed by the company and may be subject to change in its sole discretion. The operating and performance characteristics of these products may vary depending on the application, installation, operating conditions and environmental factors. The company's terms and conditions of sale can be viewed at <http://www.altramotion.com/terms-and-conditions/sales-terms-and-conditions>. These terms and conditions apply to any person who may buy, acquire or use a product referred to herein, including any person who buys from a licensed distributor of these branded products.

©2019 by TB Wood's LLC. All rights reserved. All trademarks in this publication are the sole and exclusive property of TB Wood's LLC or one of its affiliated companies.